

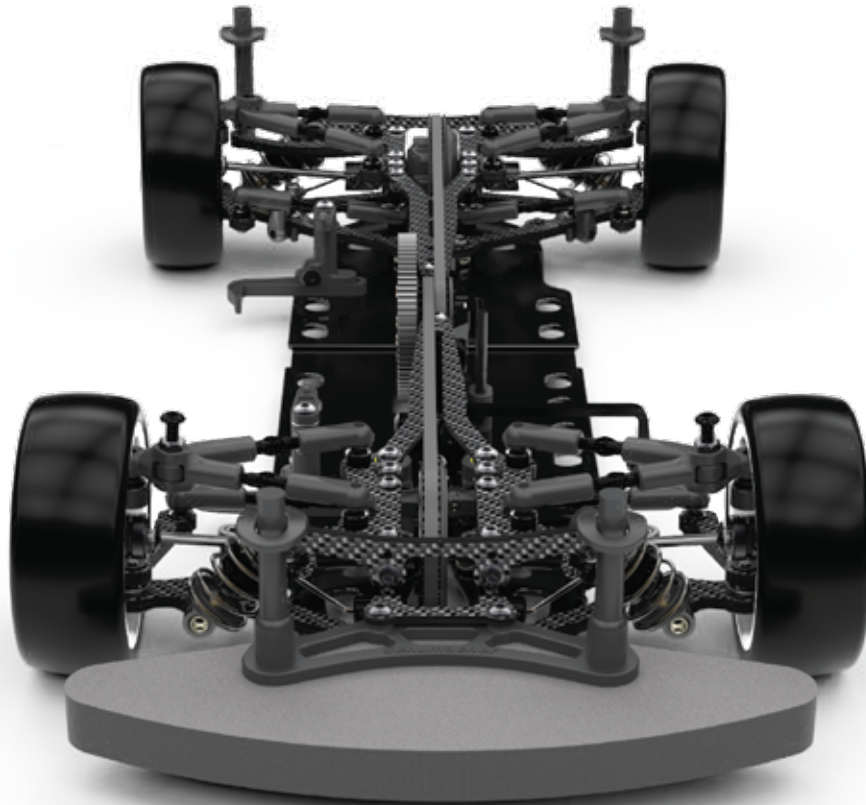

1/10TH SCALE 4WD PRO TOURING CAR



Instruction Manual ISS01



www.racing-cars.com

Schumacher

71-73 Tenter Road
Moulton Park
Northampton
NN3 6AX

IMPORTANT SAFETY NOTES

- We strongly recommend that anyone driving RC cars, or organising events, should obtain third party liability insurance. In the UK this can be done by joining the BRCA. www.brca.org
- This product is not suitable for children under the age of 14, without the direct supervision of a responsible adult.
- Select an area for assembly that is away from the reach of small children.
- The parts in this kit are small and can be swallowed by children causing choking and possible internal injuries.
- Exercise care when using hand tools and sharp instruments during assembly.
- Carefully read all manufacturers warnings and cautions for any additional items used in the construction.
- In line with our policy of continuous development the exact details of the kit may vary.
- DO NOT use this car on public roads or in places where it can interfere with traffic, people or animals.
- Always check the operation of the radio with the wheels off the ground, before using the car.
- Make sure the radio and car batteries are fully charged before use.
- Disconnect and remove the battery from the car when not in use.
- Always store and charge LiPo batteries in a fireproof container.
- DO NOT put fingers or any objects inside rotating or moving parts as this may cause injury.
- Make sure the charger is correctly set for the type of battery you are using.
- Incorrect charging may cause a fire.
- Insulate all exposed electrical wiring. Exposed or damaged wires can cause short circuits and fire.
- The motor and speed controller can become hot during use. DO NOT touch them immediately after using your car as this may cause injury.

ADDITIONAL ITEMS REQUIRED



2S LiPo Battery



Motor and Pinion Gear



Electronic Speed Controller



Battery Charger



Radio Equipment



Steering Servo



Tyre/CA Glue



Bodyshell



Polycarbonate Paint



Tyres and Inserts

RECOMMENDED TOOLS REQUIRED

1.5mm Hex Driver - U2789

2.0mm Hex Driver - U2790

2.5mm Hex Driver - U2791

3.0mm Hex Driver - U2792

5.5mm M3 Nut Driver - U2795

7.0mm M4 Nut Driver - U2796

Body Reamer - U2818

Pliers - CR528

Side Cutters - CR527

Soldering Iron - CR275

Solder - U3107

Curved Scissors - CR044

Circlip Pliers - CR878



ICON KEYS



CORE RC High Performance Lithium Grease 10ml - CR752



CORE RC Medium Strength Thread Lock 3ml - CR520



Caution/Important note. Please read.



Front Left of car.



Front Right of car.



Rear Left of car.



Rear Right of car.



Additional information that will help you build a faster race car.



Reference to Track Settings Pages 29 to 34.



Transmission Housings Assembly

BAG A - Step 1

A x12

M3 x 6 Csk Hd Screw



Please note that the Alloy Chassis is illustrated in this manual. Build the Carbon Fibre version using the same process unless illustrated.

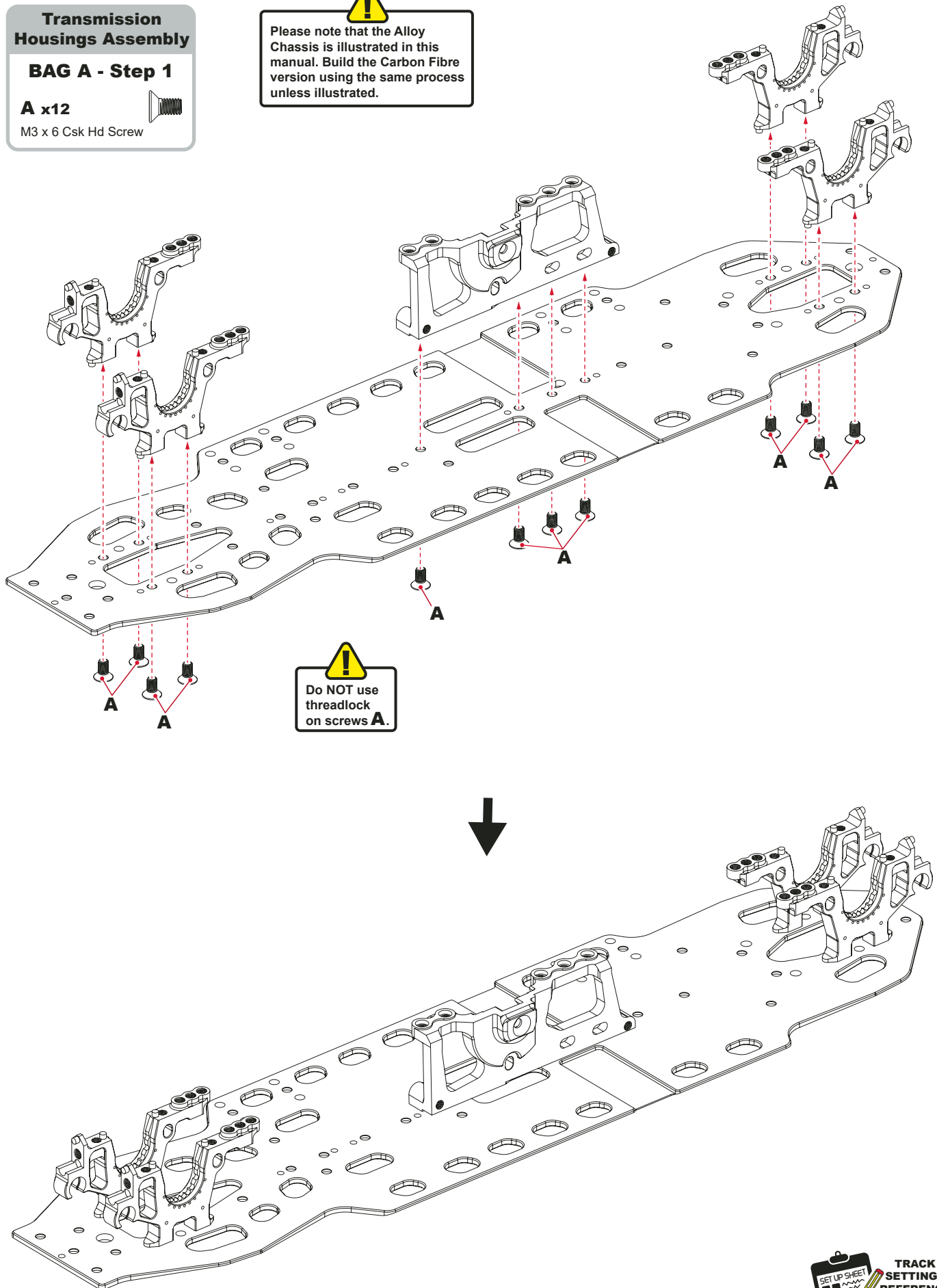

Do NOT use threadlock on screws **A**.

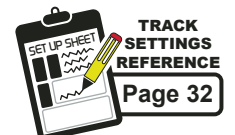

TRACK SETTINGS REFERENCE
Page 32



Differential Assembly

BAG A - Step 2

A x2

'O' Ring 3.0 x 2.0

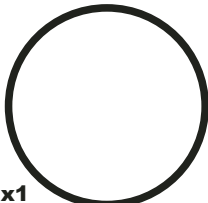

B x1

'O' Ring ø25.00 x 1.0

C x2

Shim ø5.1 x ø6.5 x 0.27



D x2

Bearing ø5 x ø8 x 2.5



E x2

'O' Ring ø7.00 x 1.0



F x2

Shim ø6.0 x ø7.7 x 0.1



G x2

Bearing ø6 x ø10 x 3



H x2

Pin ø1.5 x 7.5

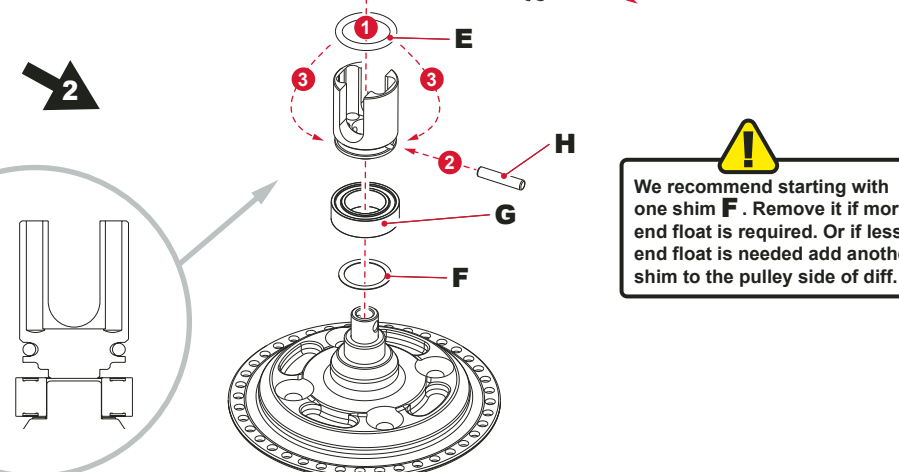
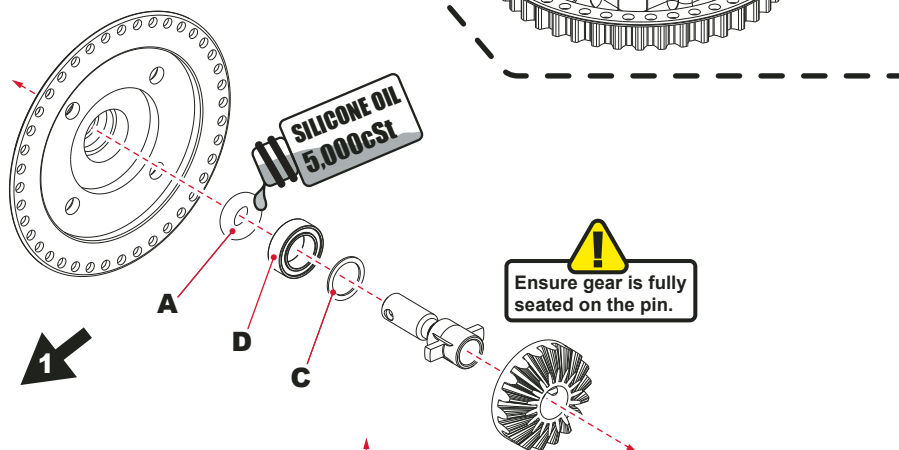
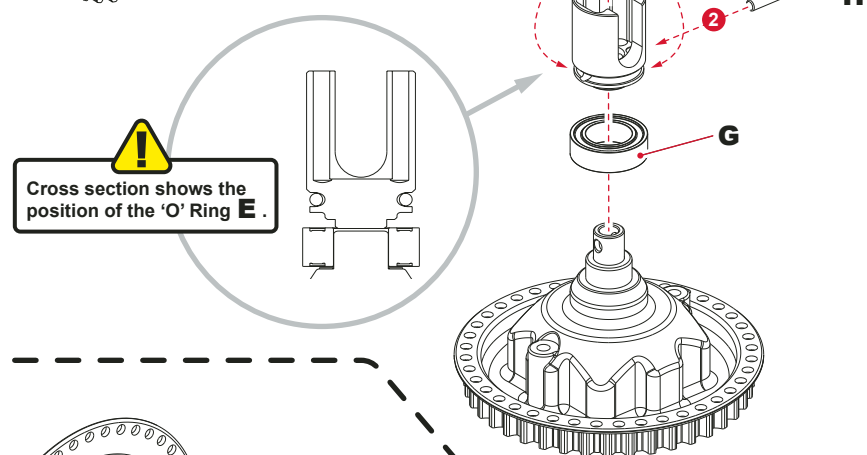
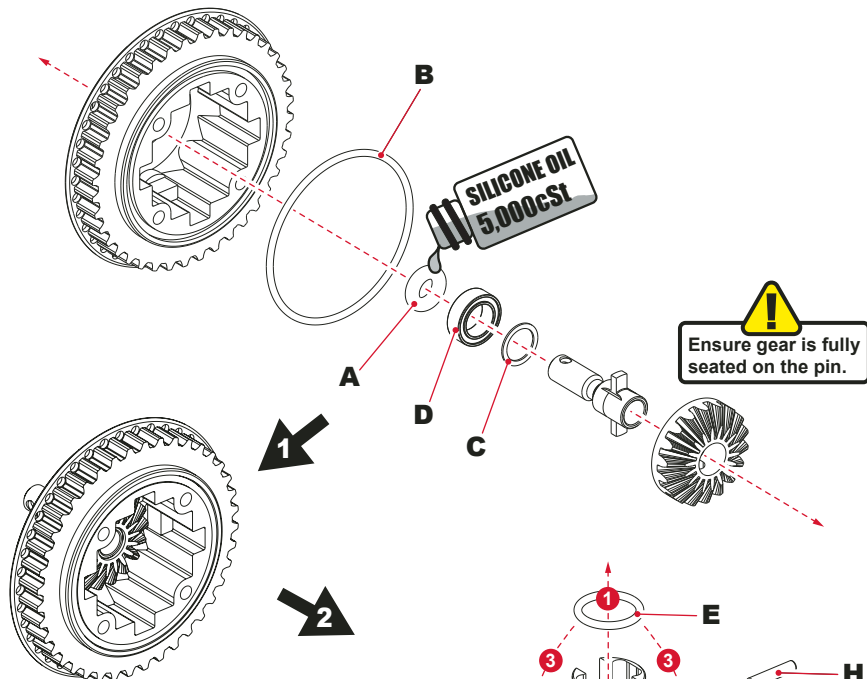

!
Cross section shows the position of the 'O' Ring E.

!
We recommend starting with one shim F. Remove it if more end float is required. Or if less end float is needed add another shim to the pulley side of diff.

Differential Assembly

BAG A - Step 3

A x4



M2.5 x 8 Csk Hd Screw

B x4



Shim $\varnothing 3.5 \times \varnothing 9.5 \times 0.1$

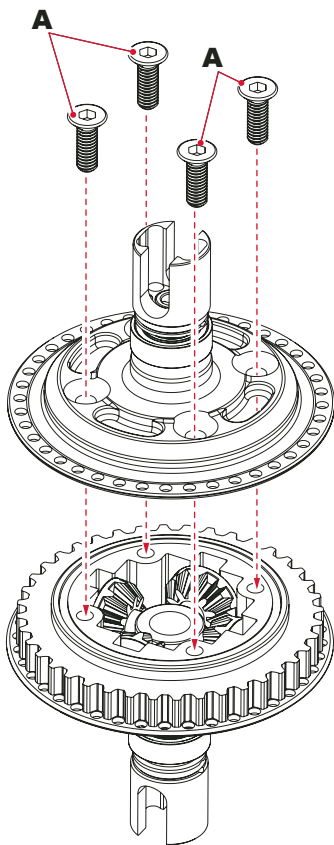
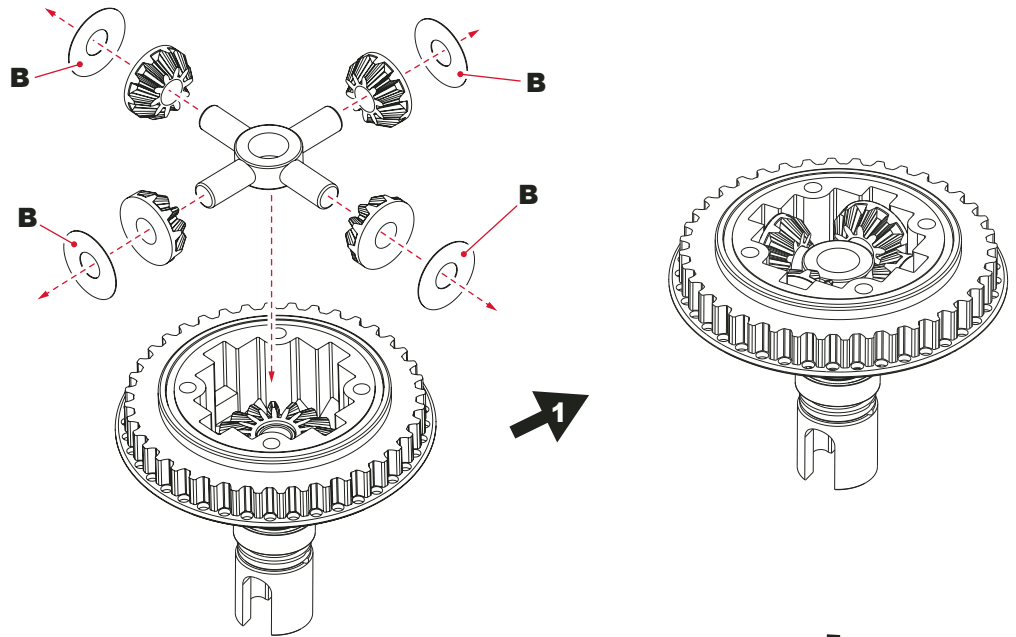

!
Use 1.6 grams of oil.
The alternative is to fill until the cross pin is covered.
DO NOT over fill.
Kit Setting is 5000cSt.

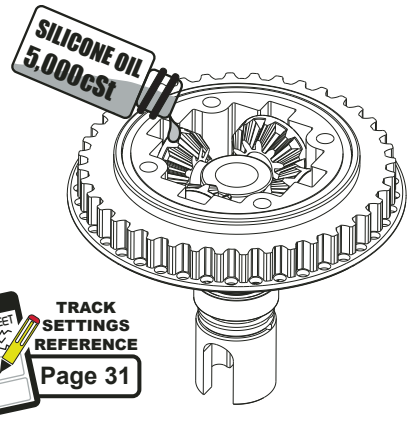

SET UP SHEET
TRACK SETTINGS REFERENCE
Page 31

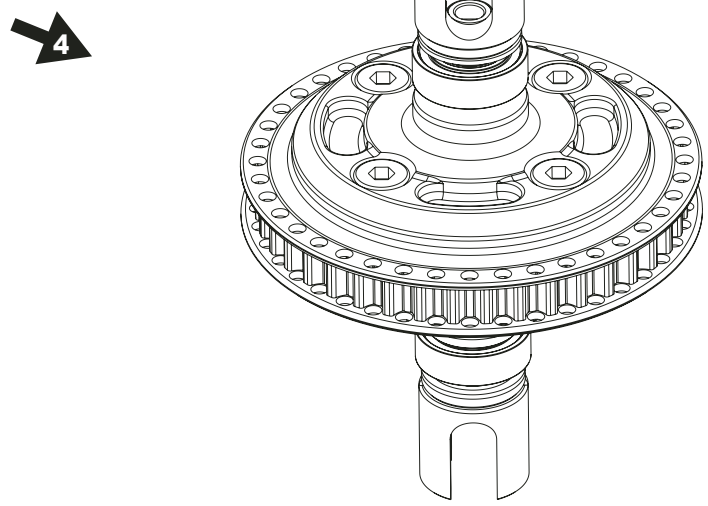

Differential Fitting
BAG A - Step 3

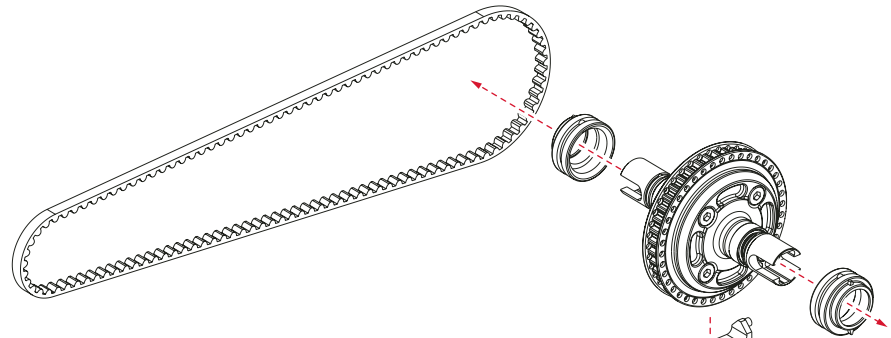

!
Make note of the position of the eccentric housings. They adjust belt tension and must be the same both sides. The recommended starting position is shown.

TRACK SETTINGS REFERENCE
Page 32

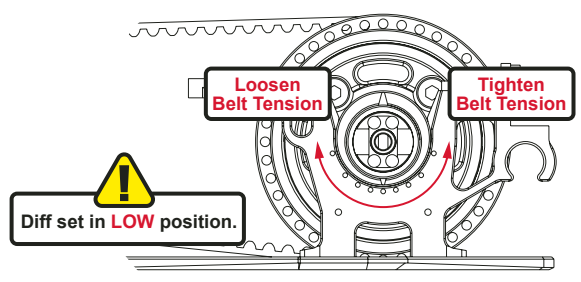
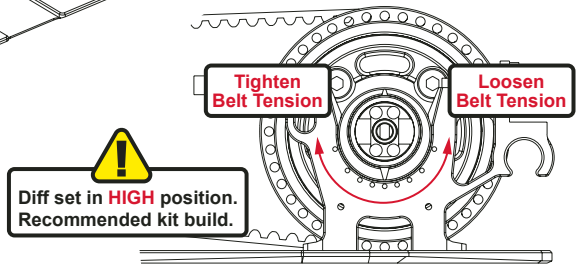
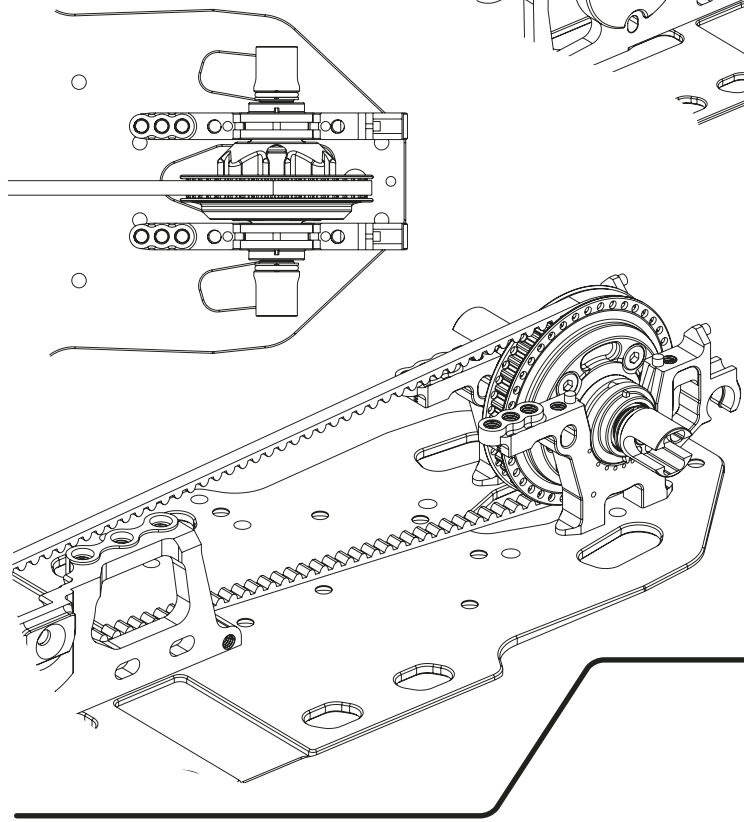

Front Spool Assembly
BAG A - Step 4a

- A x2**
M3x 8 Csk Hd Screw
- B x3**
M3x 5 Pan Hd Screw
- C x2**
Shim $\varnothing 7.7 \times \varnothing 6.0 \times 0.1$
- D x2**
Bearing $\varnothing 6 \times \varnothing 10 \times 3$

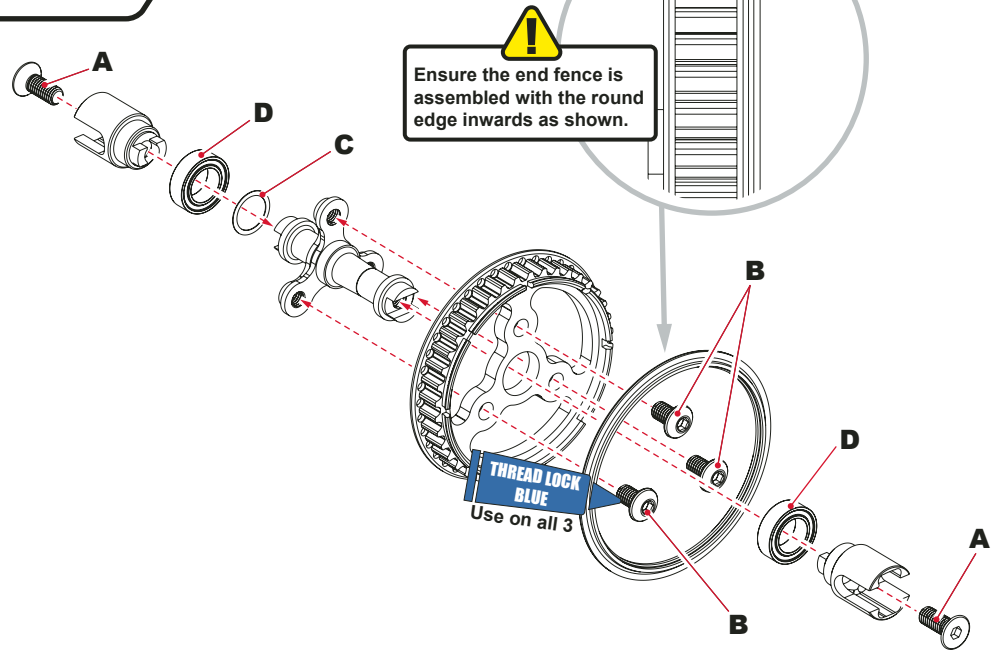

Front Spool Fitting

BAG A - Step 4



Make note of the position of the eccentric housings. They adjust belt tension and must be the same both sides. The recommended starting position is shown.

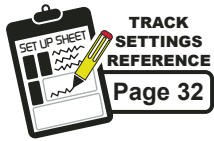
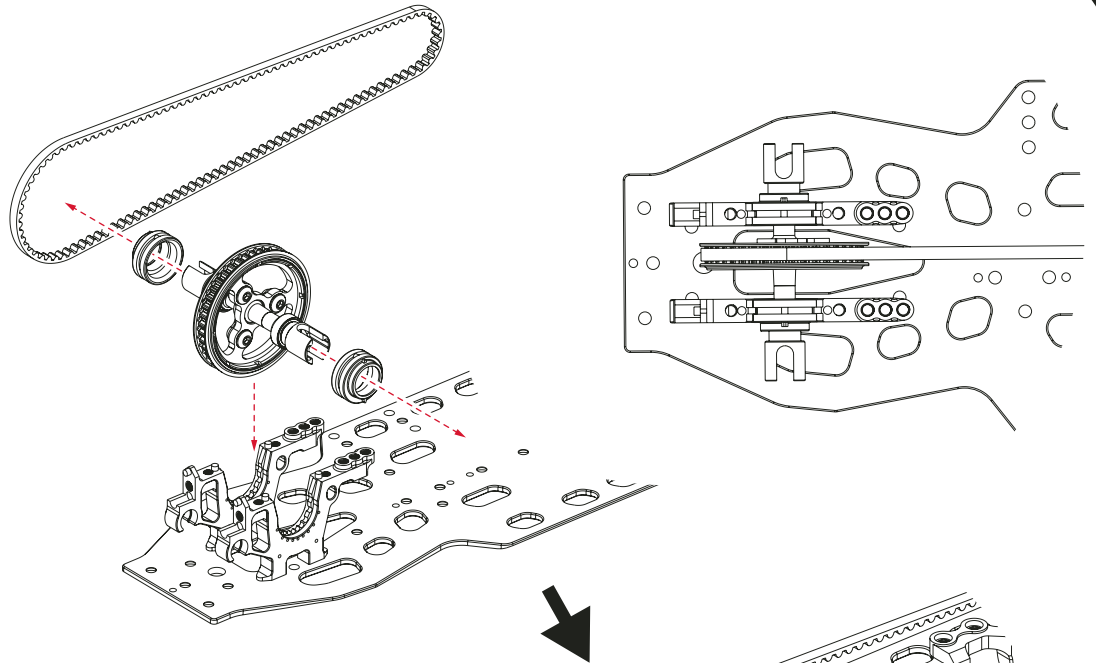

Loosen Belt Tension

Tighten Belt Tension



Spool set in **HIGH** position. Recommended kit build.

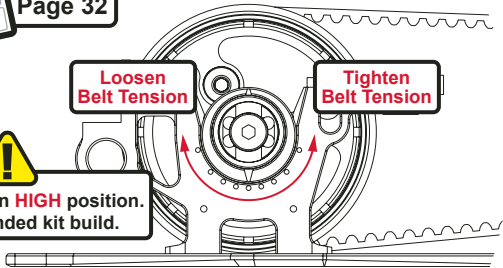

Tighten Belt Tension

Loosen Belt Tension



Spool set in **LOW** position.

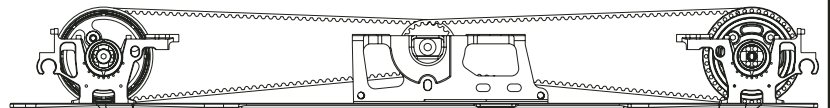
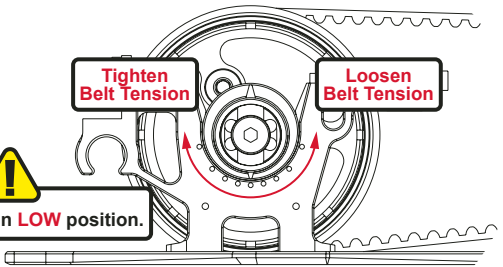

Pulley & Spur Assembly

BAG A - Step 5

A x1

M3x 8 Csk Hd Screw



B x1

M3x 4 Button Hd Screw



C x1

Bearing $\phi 3/16"$ x $\phi 5/16"$ Flanged



D x1

Bearing $\phi 3/16"$ x $\phi 5/16"$



E x3

Spur Gear Screw



A

Seat shaft fully into the slot.

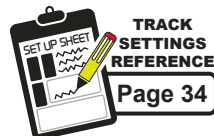
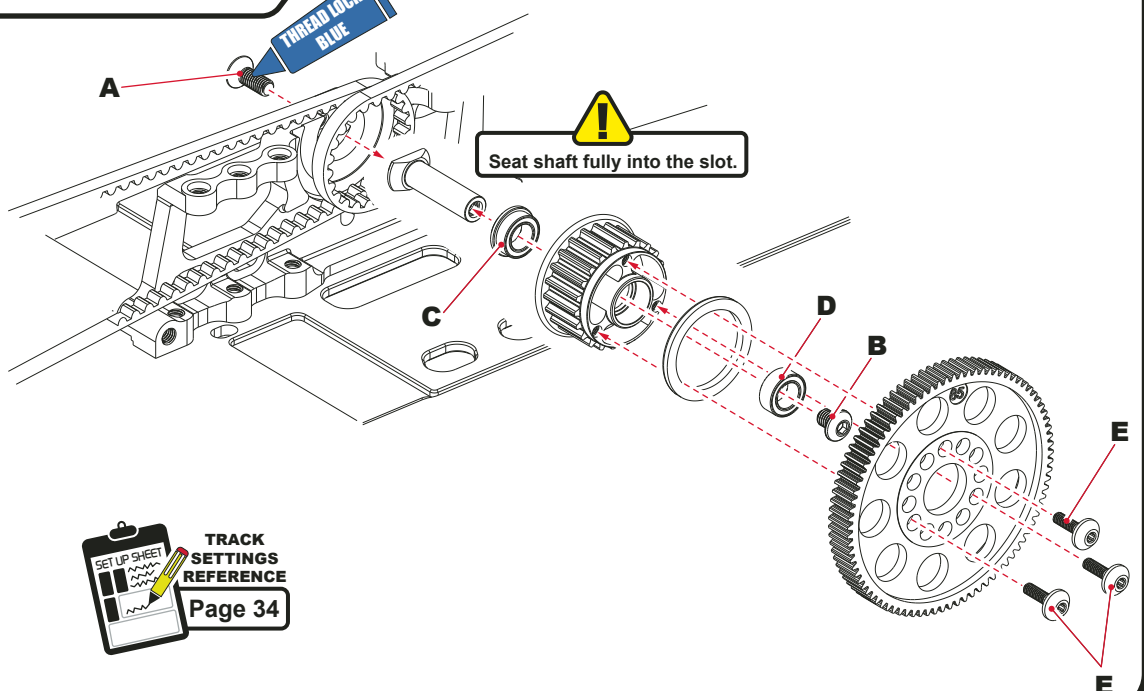

**Pulley & Spur
Complete**

BAG A - Step 5

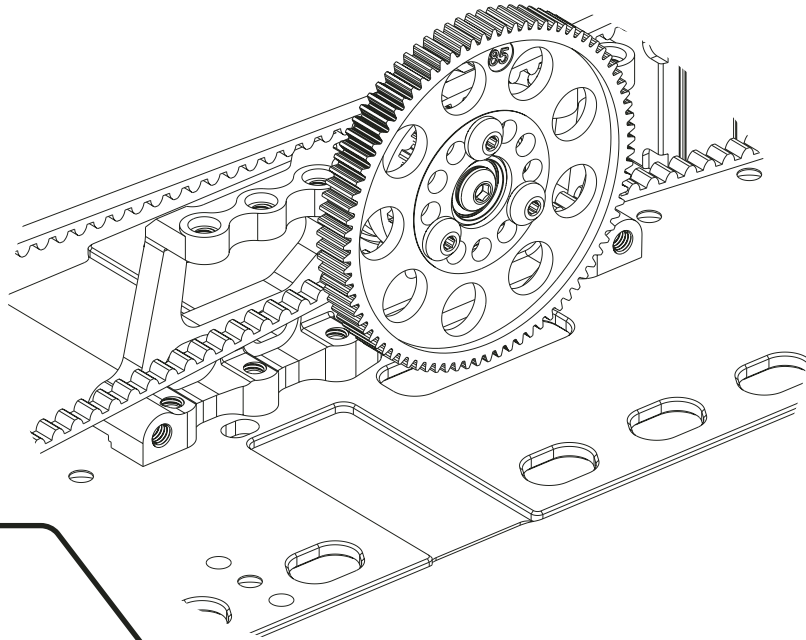

**Rear Shock Mount
Assembly**

BAG A - Step 6a

A x2 
M3x 6 Button Hd Screw

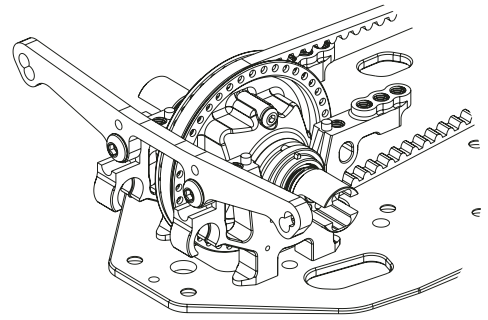
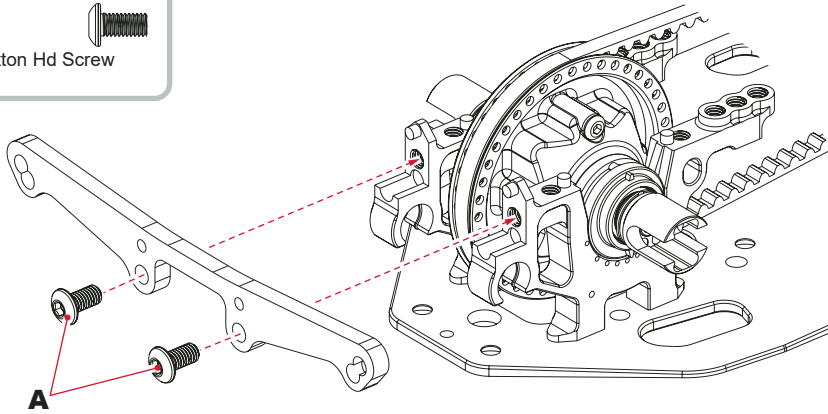

**Front Shock Mount
Assembly**

BAG A - Step 6b

A x2 
M3x 6 Button Hd Hd Screw

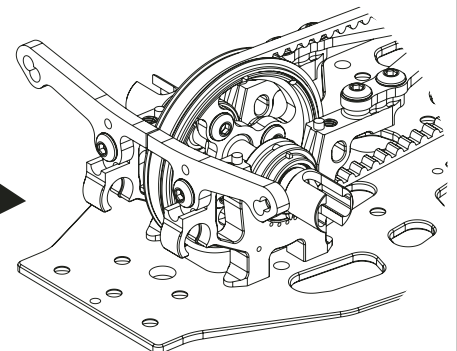
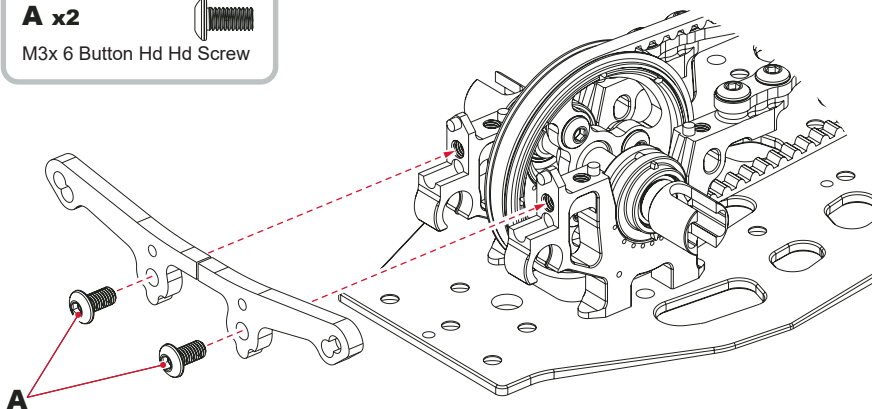

Top Deck Assembly

BAG A - Step 6c

A x10 
M3x 6 Button Hd Hd Screw

B x2 
Dowel Bush

ALLOY CHASSIS

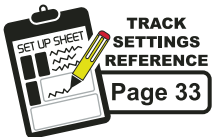
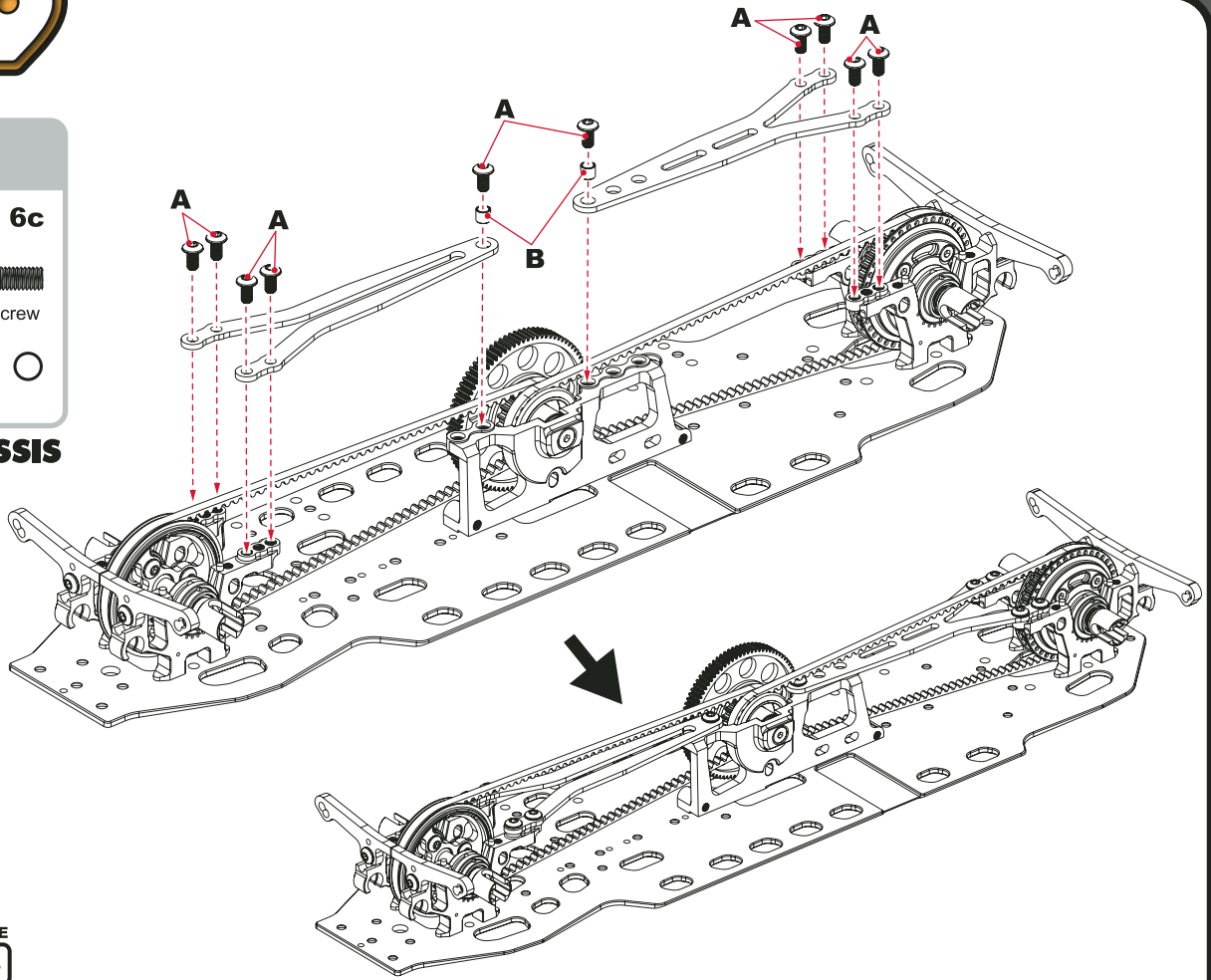

Top Deck Assembly

BAG A - Step 6c

A x9 
M3x 6 Button Hd Hd Screw

B x1 
Dowel Bush

CARBON CHASSIS

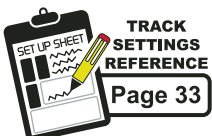
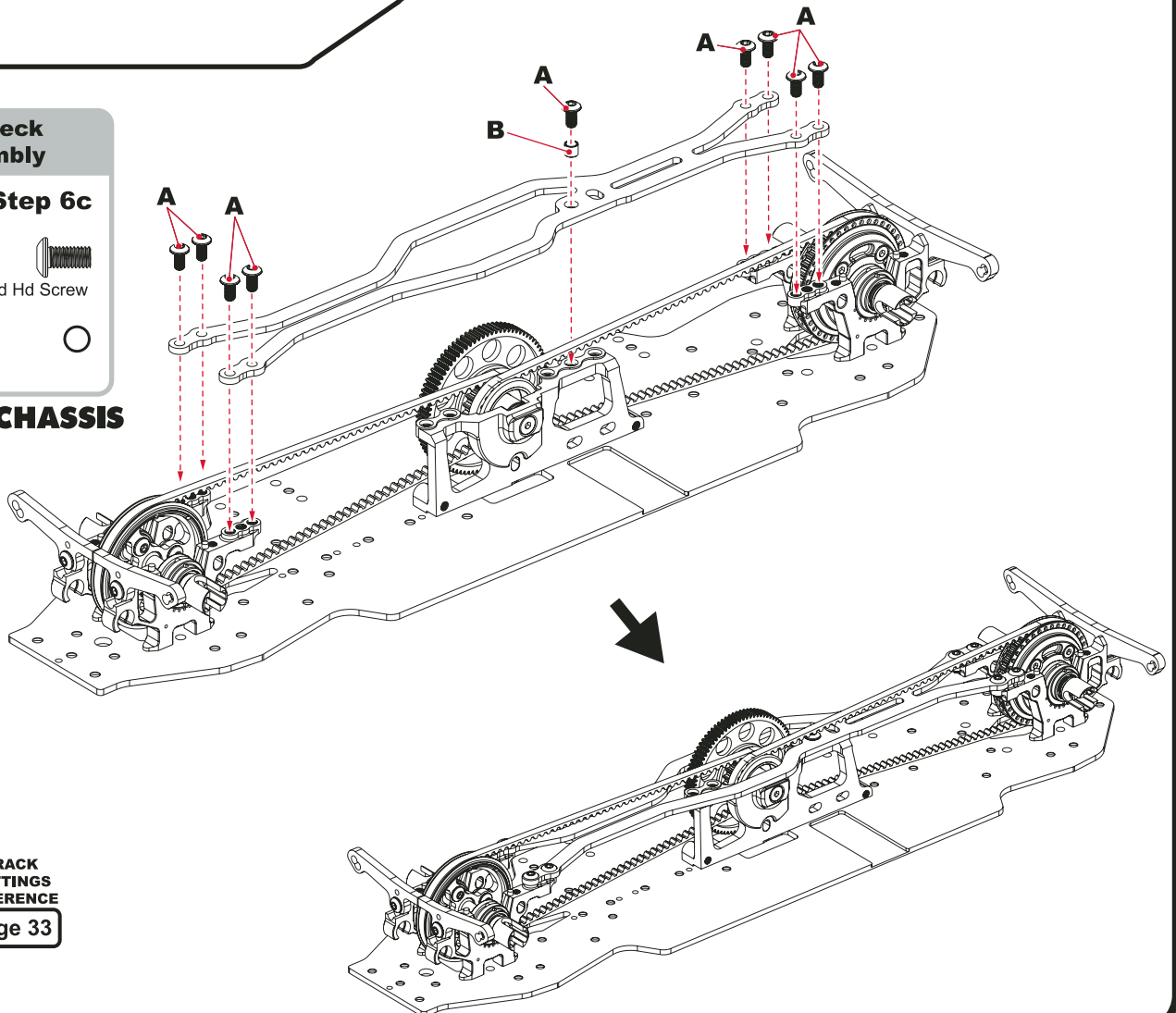

Front & Rear Link Mount Assembly

BAG A - Step 7a

A x1

M3 x 8 Cap Hd Screw

B x3

M3 Washer

C x8

Black 1.0 mm

D x8

Long Ball Stud (Low)

E x8

Black 2.0 mm

F x8

M3 Thread Insert

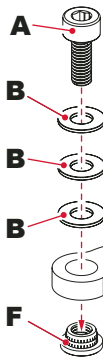

!
Use screw 'A' and washers 'B' to fit the inserts 'F'. (Keep 'A' and 'B' safe for later.)

Pre-Fit Inserts

!
Tighten screw 'A' until the M3 thread insert 'F' is pulled into the carbon fibre parts as shown.

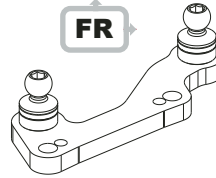
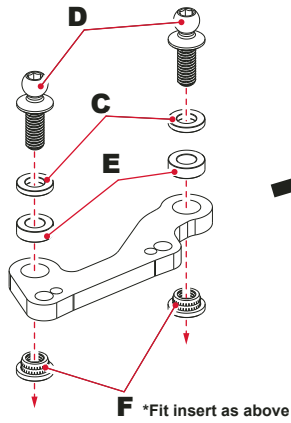

SET UP SHEET
TRACK SETTINGS REFERENCE
Pages 31 & 33

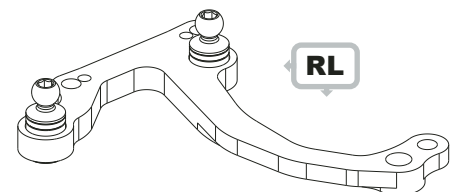
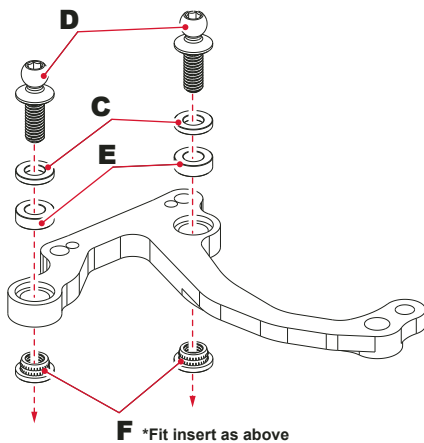
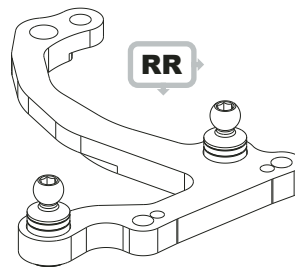
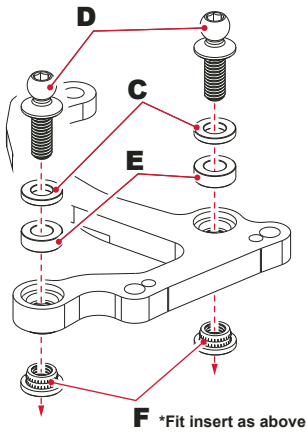
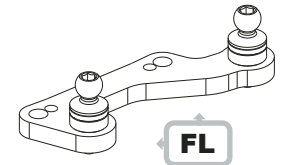
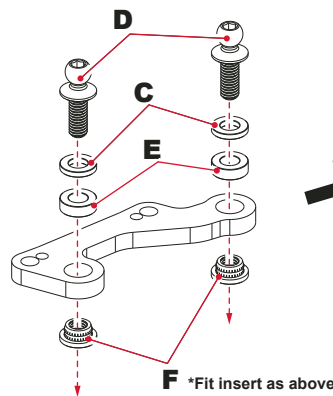

Front & Rear Link Mount Fitting

BAG A - Step 7b

A x4
M3 x 6 Button Hd Screw

B x4
M3 x 8 Button Hd Screw

!
Spool set in **HIGH** position.
Recommended kit build.

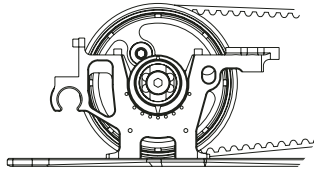

!
Diff set in **HIGH** position.
Recommended kit build.

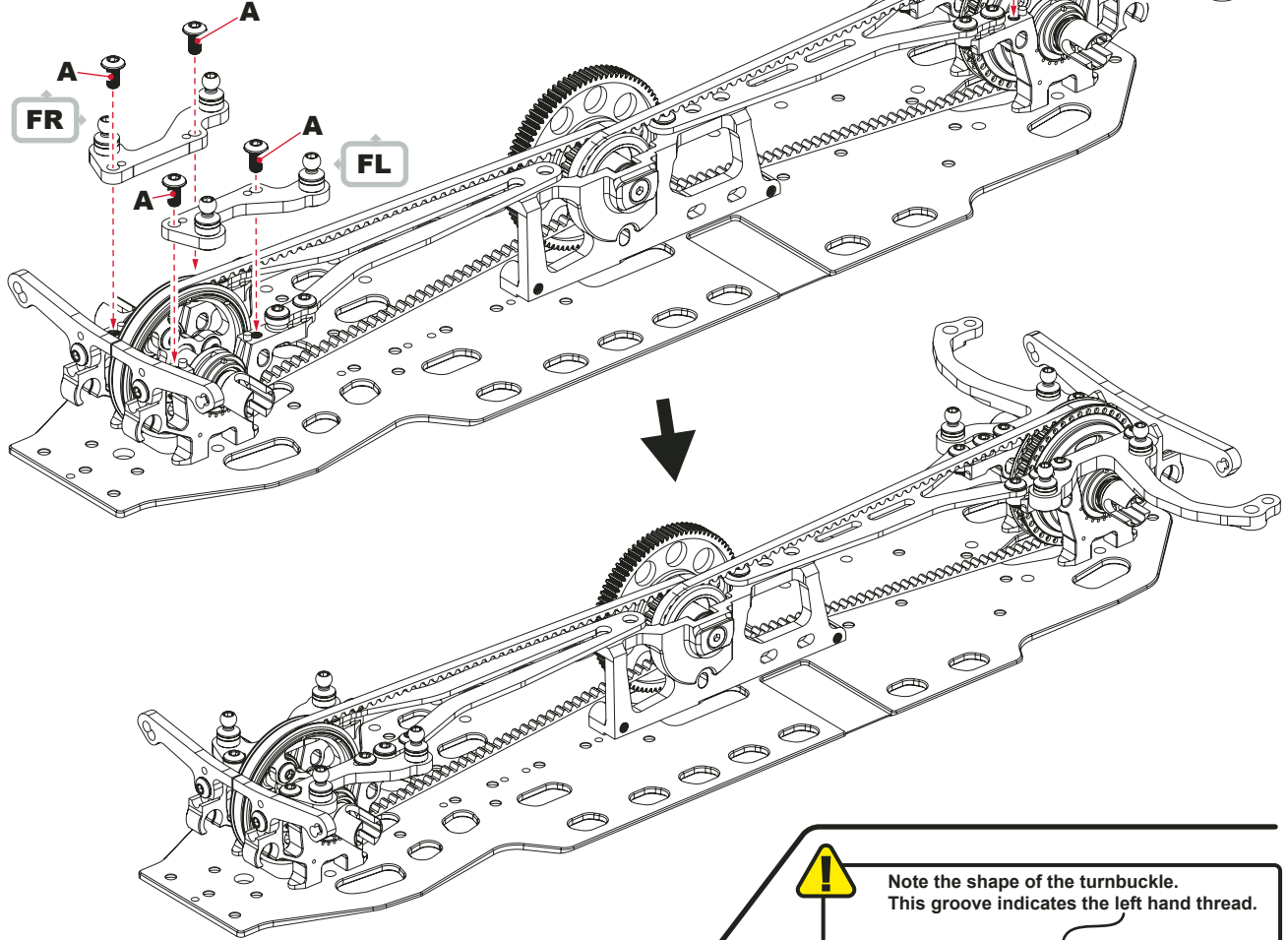
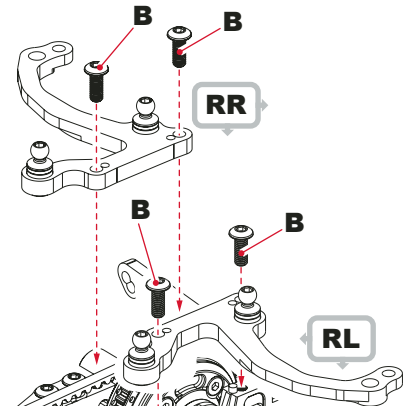
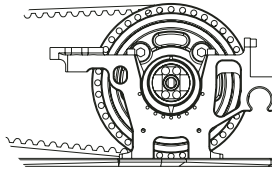

! Note the shape of the turnbuckle. This groove indicates the left hand thread.

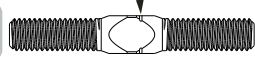
RH Thread  **LH Thread**

! Put aside the completed front turnbuckles until required for Step 17.

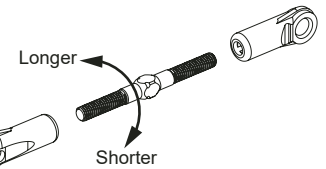

Turnbuckle Assembly

BAG A - Step 8a

Turnbuckle Lengths (mm)	x	y
Front (FL&FR)	26.2	45
Rear (RL&RR)	17.7	35

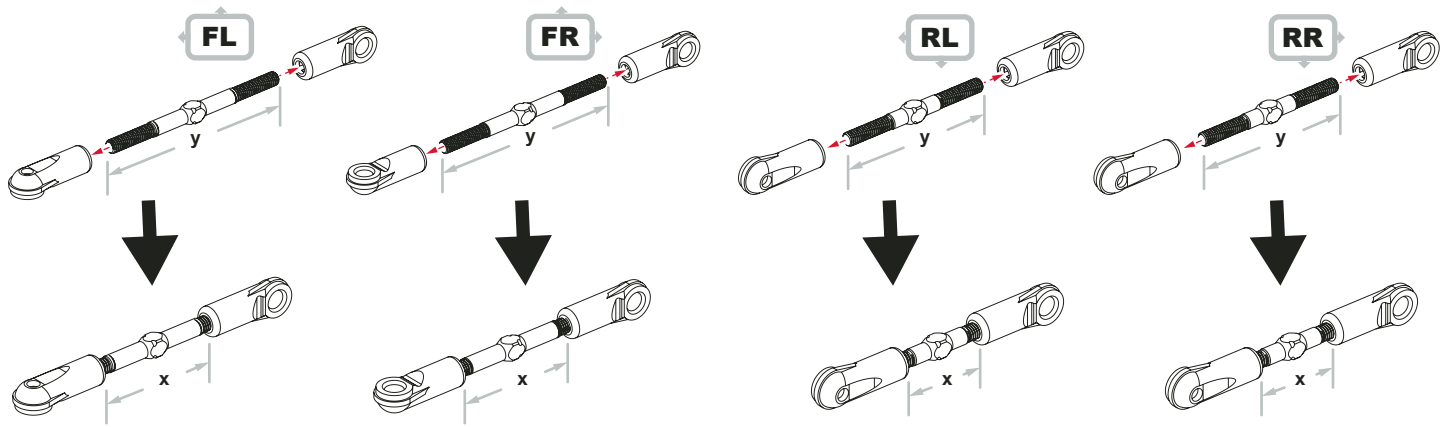

Rear Toe-Link Fitting

BAG A - Step 8b

- A x2** Long Ball Stud (Low)
- B x2** M3 Alloy Spacer 3.0mm

Fit Rear Links from Step 8a

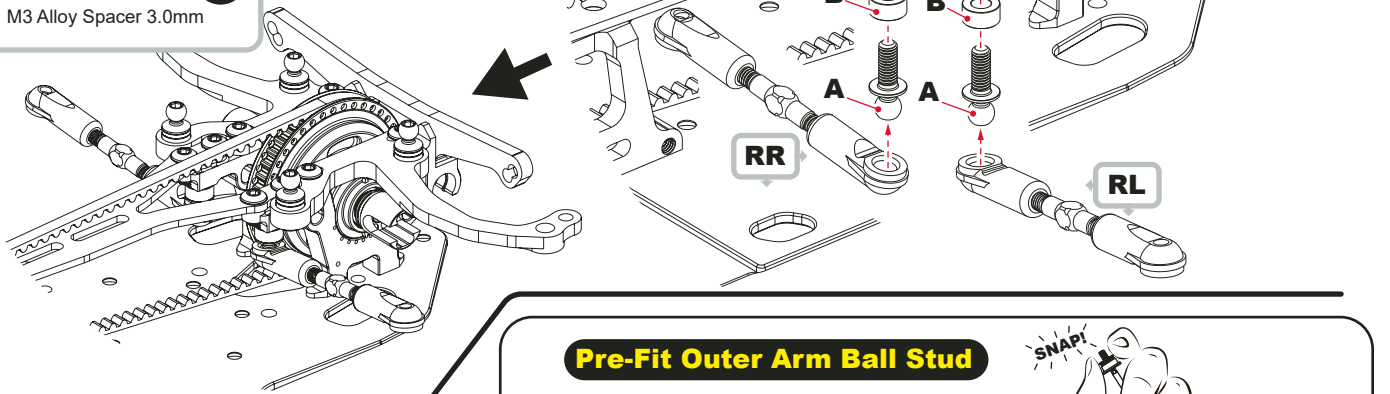

Pre-Fit Outer Arm Ball Stud

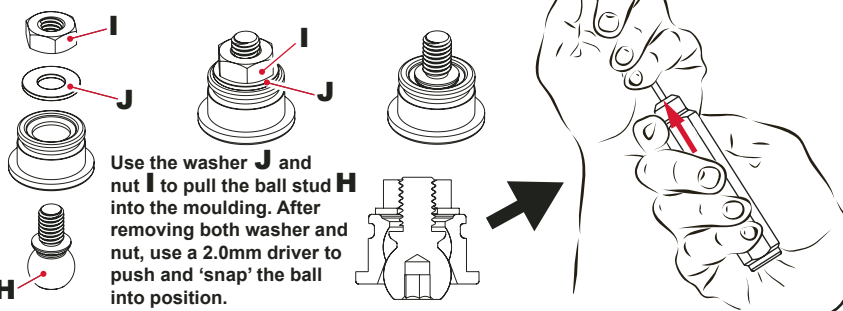

Front Lower Wishbone Assembly

BAG B - Step 9

- A x2** M3 x 6 Button Hd Screw
- B x2** M3 x 10 Button Hd Screw
- C x2** M3 Black Thread Insert
- D x2** M3 x 8 Patched Dome Point Grub Screw
- E x2** M3 x 8 Cup Point Grub Screw
- F x6** O'ring ø5 x 1.0
- G x4** 5.5mm Wishbone Ball
- H x2** Outer Arm Ball Stud
- I x1** M3 Nut
- J x1** M3 Steel Washer

! Set the grub screws 'D' centrally for now. This is adjusted to set droop using a droop gauge later.

! Pre-Fit Inserts as per Page 9

Ensure the 'O' ring is correctly seated into the groove on the sockets. Use pliers to insert ball 'G' into its socket easily.

! Pre-Fit as above

! Build a pair of these. The FL side is a mirror of the FR build.

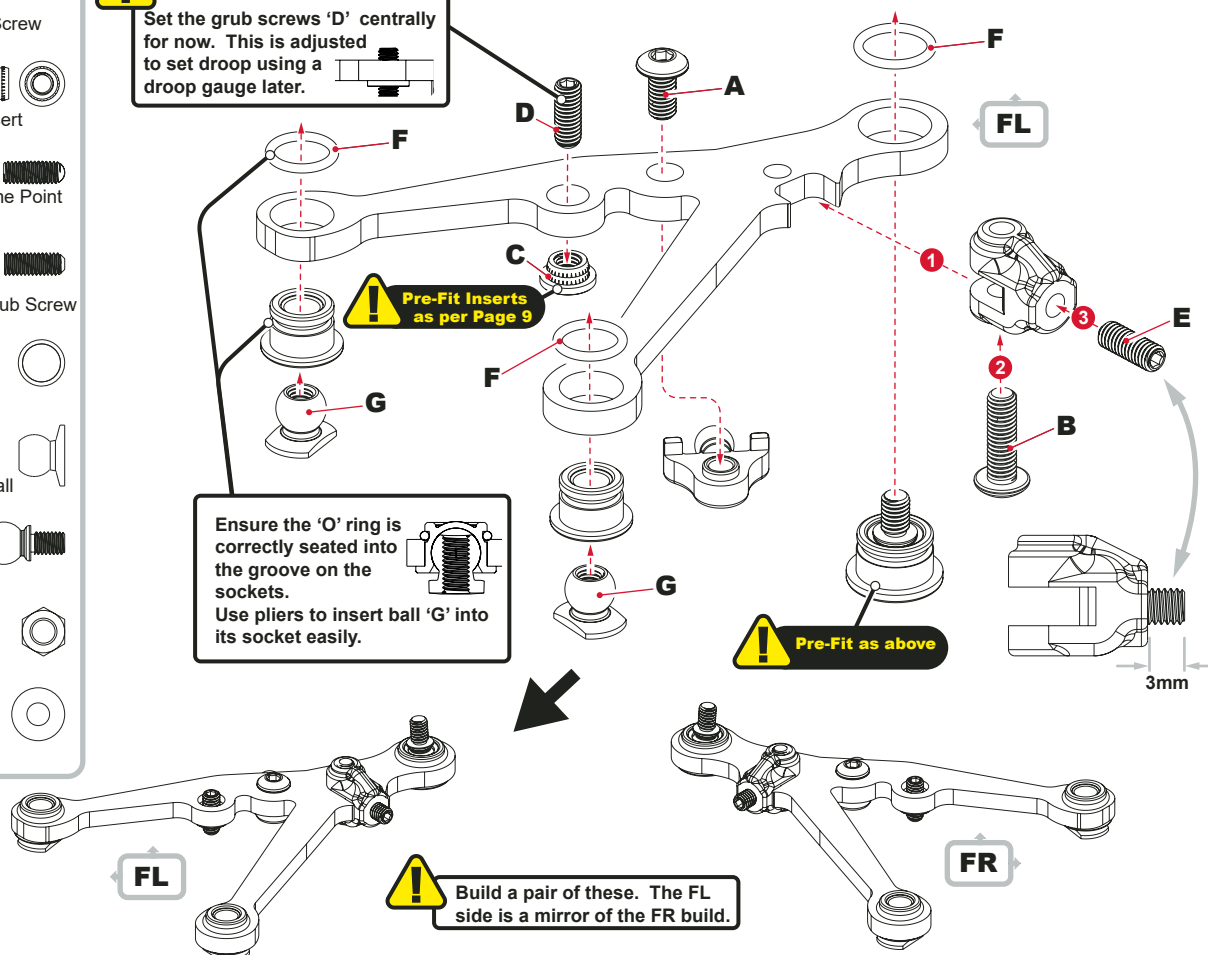

Rear Lower Wishbone Assembly

BAG B - Step 10

A x2
M3 x 6 Button Hd Screw

B x2
M3 x 10 Button Hd Screw

C x2
M3 Black Thread Insert

D x2
M3 x 8 Patched Dome Point Grub Screw

E x2
M3 x 8 Cup Point Grub Screw

F x6
O'ring ø5 x 1.0

G x4
5.5mm Wishbone Ball

H x2
Outer Arm Ball Stud

! Set the grub screws 'D' centrally for now. This is adjusted to set droop using a droop gauge later.

SET UP SHEET
TRACK SETTINGS REFERENCE
Page 31

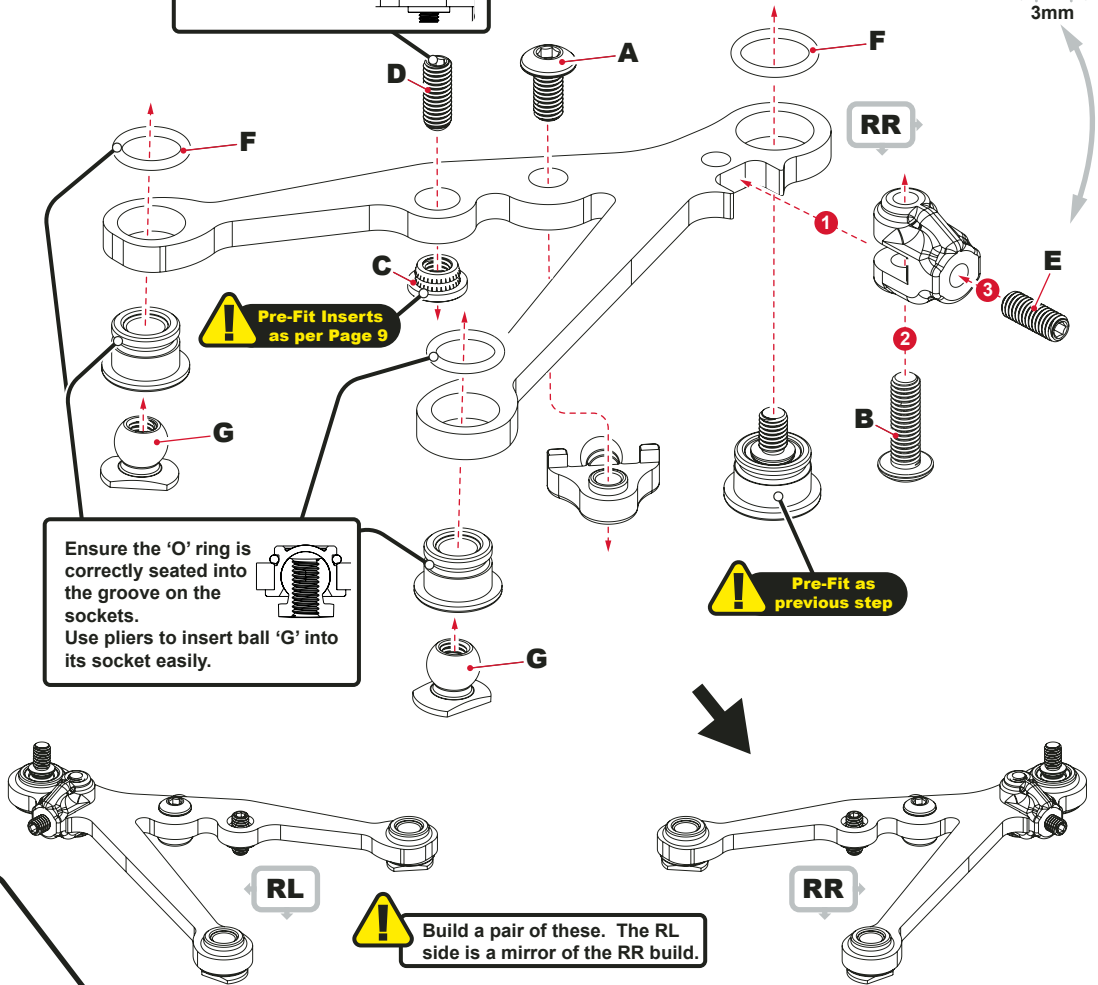
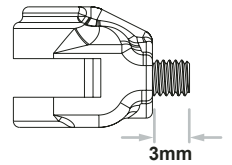

Lower Wishbone Fitting

BAG B - Step 11

A x8
M3 x 8 Csk Hd Screw

B x2
M3 Alloy Spacer 0.5mm

C x6
M3 Alloy Spacer 1.0mm

! Some parts have been hidden for clarity.

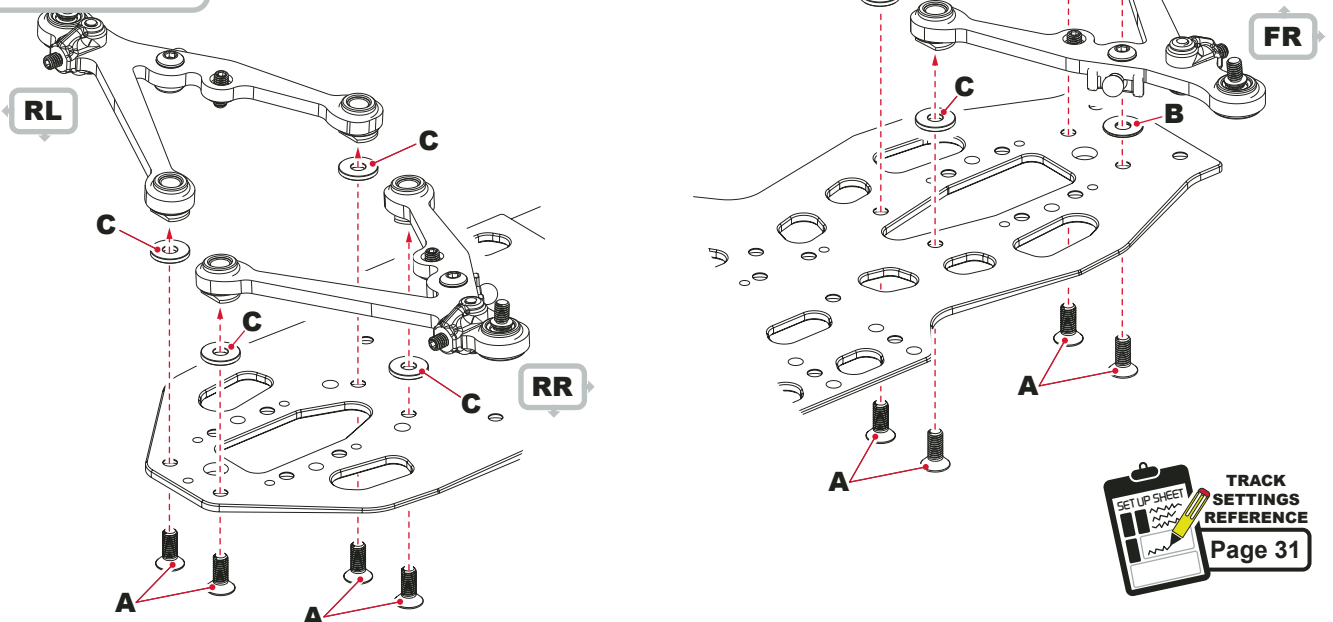

SET UP SHEET
TRACK SETTINGS REFERENCE
Page 31



Front Driveshaft Assembly

BAG B - Step 12

- A x4** Driveshaft Pin 7.3 x 1.5mm
- B x6** 'E' clip M1.2
- C x4** Ball Bearing 1.5 x 4 x 2mm
- D x2** Needle Roller 1.5 x 7.8mm

Note orientation.

We recommend the use of Internal Circlip Pliers to ease assembly. Such CORE RC CR878.

Be careful not to over stretch the clip.

Note orientation.

Assemble two.

Note orientation.

Rear Driveshaft Assembly

BAG B - Step 13

- A x4** Driveshaft Pin 7.3 x 1.5mm
- B x6** 'E' clip M1.2
- C x4** Ball Bearing 1.5 x 4 x 2mm
- D x2** Needle Roller 1.5 x 7.8mm

Note orientation.

Assemble two.

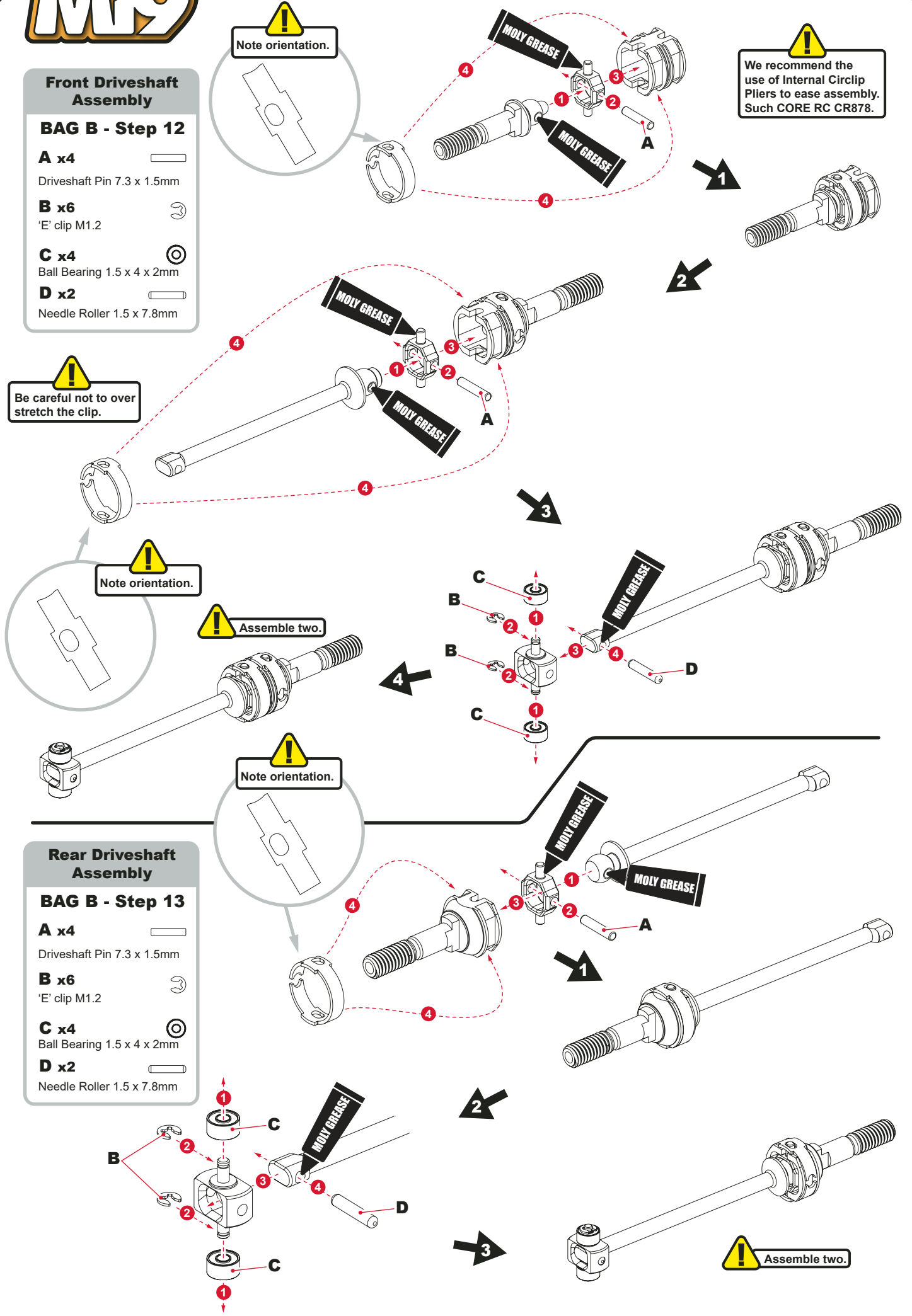

Front Hub Assembly

BAG B - Step 14

A x4 

M3 x 8 Button Hd Screw

B x2 

M3 Alloy Nyloc Nut

C x2 

M3 Black Thread Insert

D x2 

'O' Ring ø3.5 x 1.0

E x4 

Bearing ø6 x ø10 x 3.0

F x4 

M3 Alloy Spacer 0.5mm

G x2 

Long Ball Stud (Low)

H x2 

Hub Bearing Spacer

 **Pre-Fit Inserts as per Page 9**

 **TRACK SETTINGS REFERENCE Page 33**

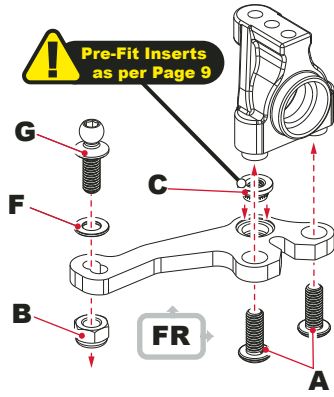

1

FR

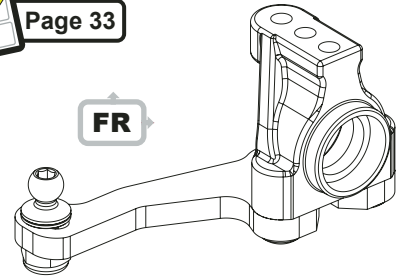

2

 **Insert the 'O' Ring D into the hex drive first.**

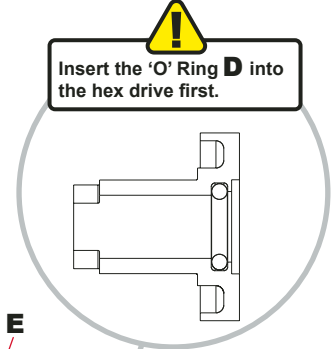

 **RACE TIP**
Rotate the hex clockwise as you push it on the axle. This will reduce the chance of the 'O' Ring falling from the hex.

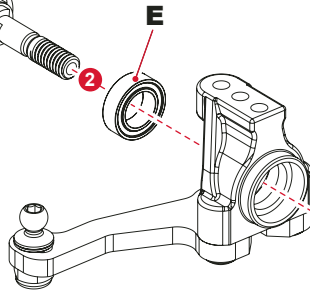

FR

3

 **Build a pair of these. The FL side is a mirror of the FR build.**

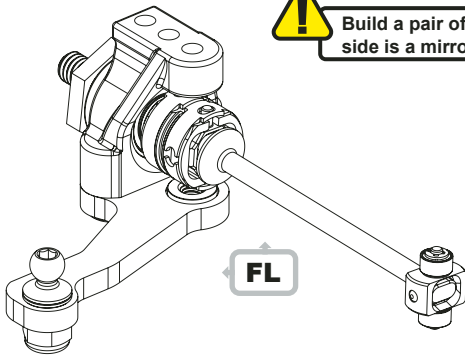

FL

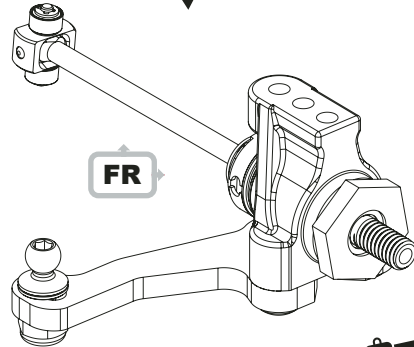

FR

 **TRACK SETTINGS REFERENCE Page 29**

4

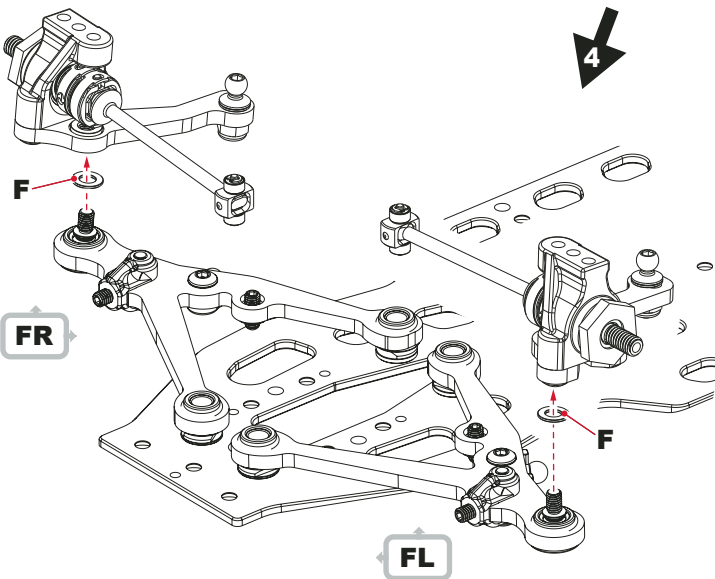

FR

FL

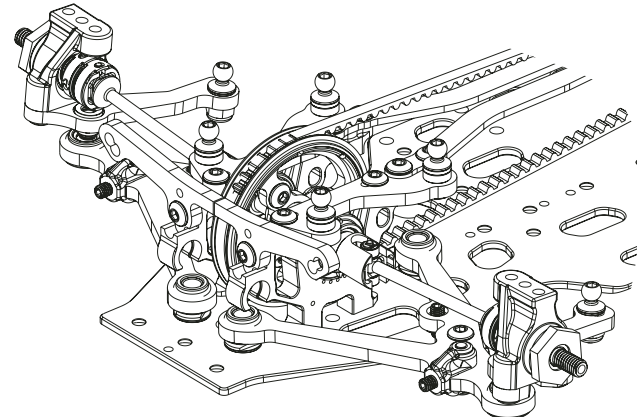



Rear Hub Assembly

BAG B - Step 15

A x4  M3 x 8 Button Hd Screw

B x2  M3 Alloy Spacer 2.0mm

C x4  M3 Black Thread Insert

D x2  'O' Ring ø3.5 x 1.0

E x4  Bearing ø6 x ø10 x 3.0

F x4  M3 Alloy Spacer 0.5mm

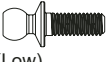
G x2  Long Ball Stud (Low)

H x2  Hub Bearing Spacer

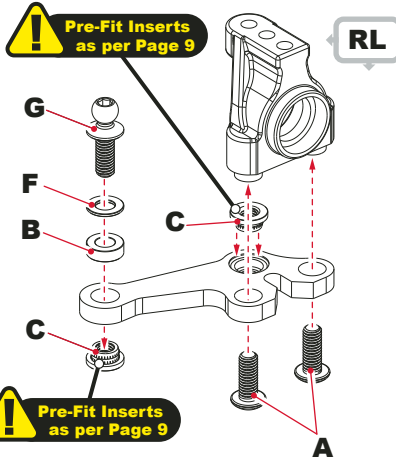

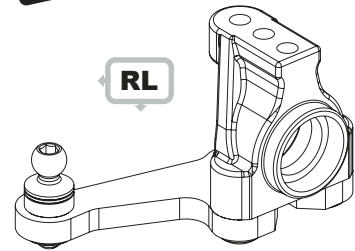

 **TRACK SETTINGS REFERENCE**
Page 30

➔ 1

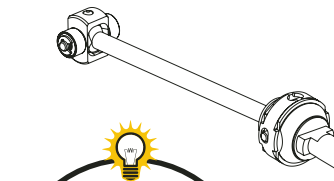

 **Pre-Fit Inserts as per Page 9**



 **RACE TIP**
Rotate the hex clockwise as you push it on the axle. This will reduce the chance of the 'O' Ring falling from the hex.

RL

➔ 2

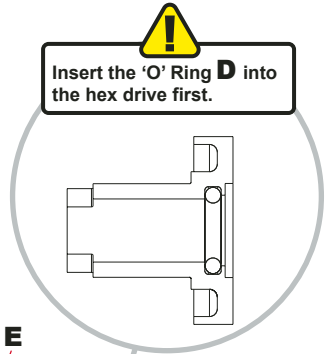

 **Insert the 'O' Ring D into the hex drive first.**

 **TRACK SETTINGS REFERENCE**
Page 29

➔ 3

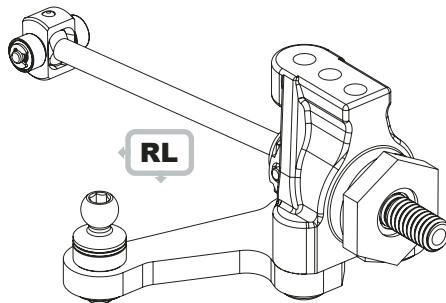

RL

 **Build a pair of these. The RR side is a mirror of the RL build.**

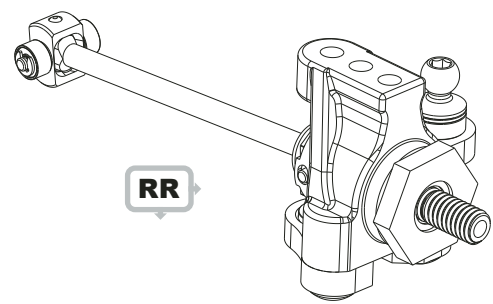

RR

➔ 4

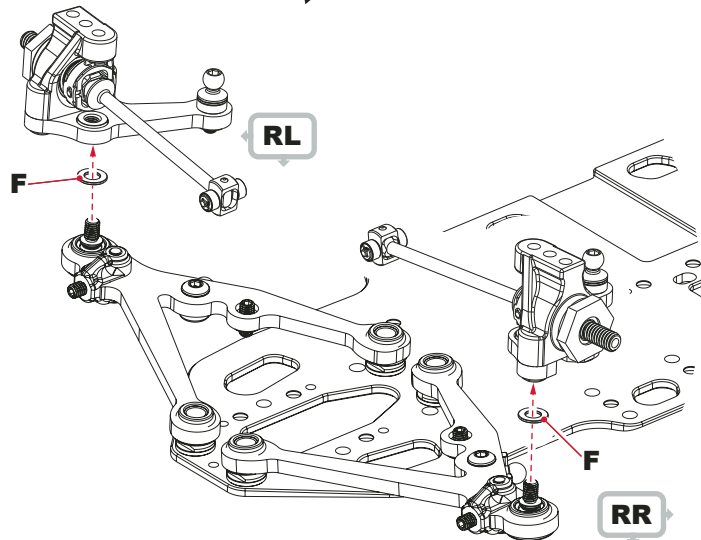

RL

RR

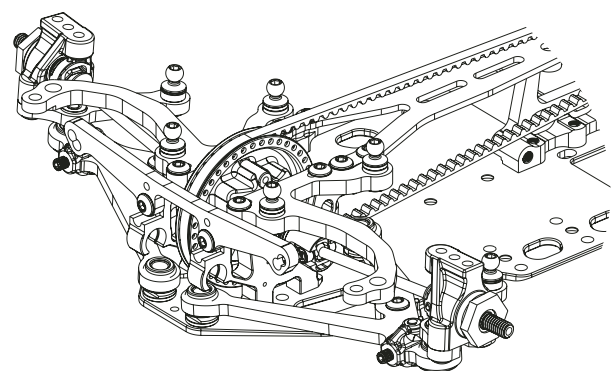

Front Upper Wishbone Assembly

BAG B - Step 16a

A x2
M3 x 8 Button Hd Screw

B x2
Alloy Upper Link Pivot (Front)

! Note the shape of the turnbuckle. This groove indicates the left hand thread.

RH Thread  **LH Thread**

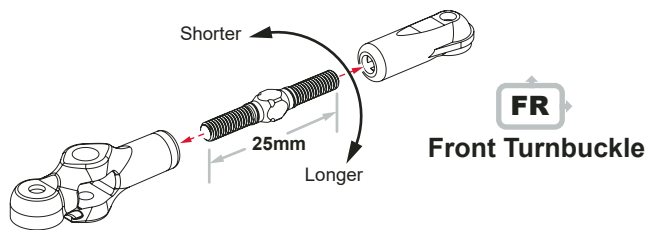
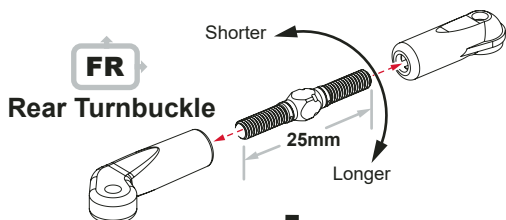

! Build a pair of these. The FL side is a mirror of the FR build.

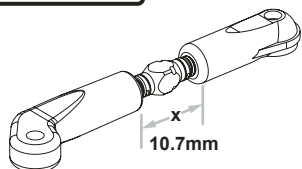

RACE TIP
Keep the left handed threads of the turnbuckles to the lefthand side of the car. This will make adjustments far easier.

! Build a pair of these. The FL side is a mirror of the FR build.

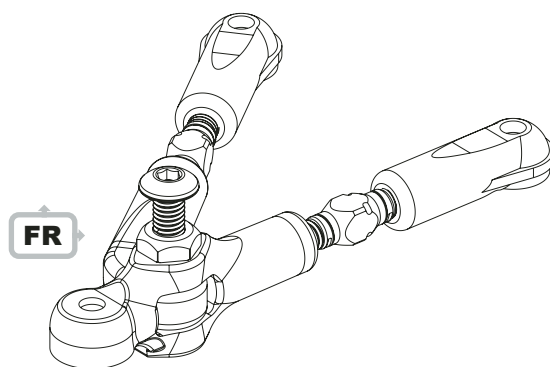
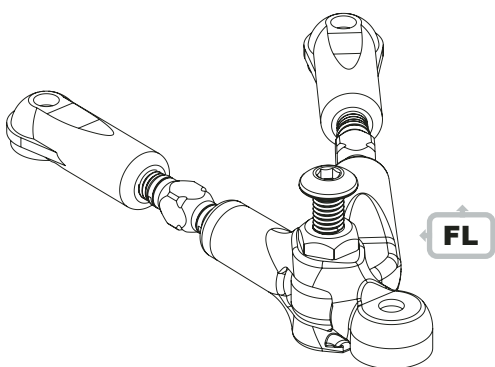
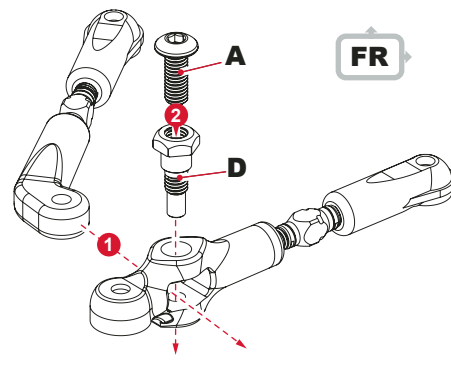
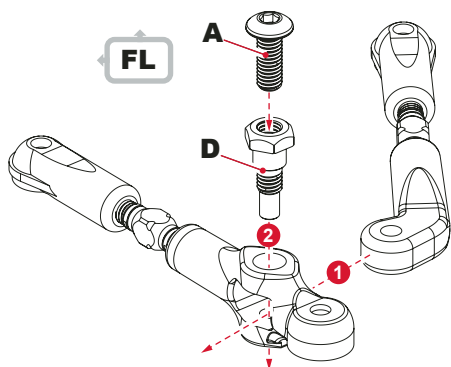
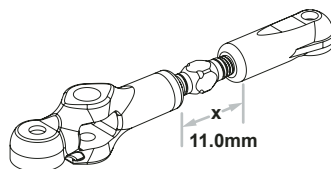

TRACK SETTINGS REFERENCE
Page 29

Rear Upper Wishbone Assembly

BAG B - Step 16b

A x2



Alloy Upper Link Pivot (Rear)

! Note the shape of the turnbuckle. This groove indicates the left hand thread.

RH Thread

LH Thread

RR
Front Turnbuckle

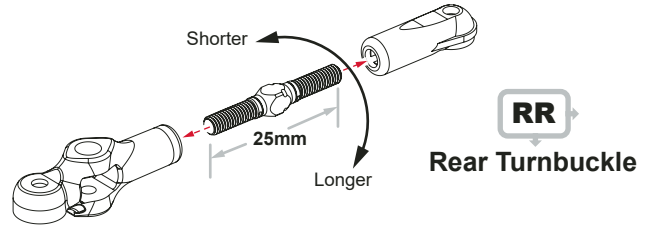
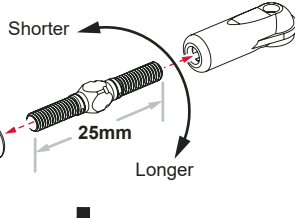

RR
Rear Turnbuckle

! Build a pair of these. The RL side is a mirror of the RR build.

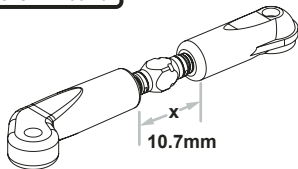

RACE TIP
Keep the left handed threads of the turnbuckles to the lefthand side of the car. This will make adjustments far easier.

! Build a pair of these. The RL side is a mirror of the RR build.

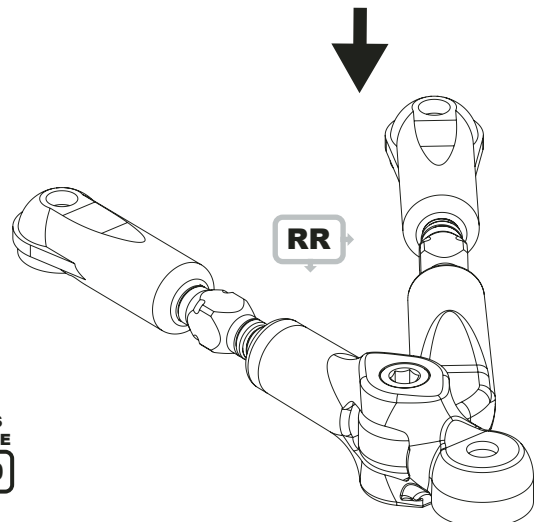
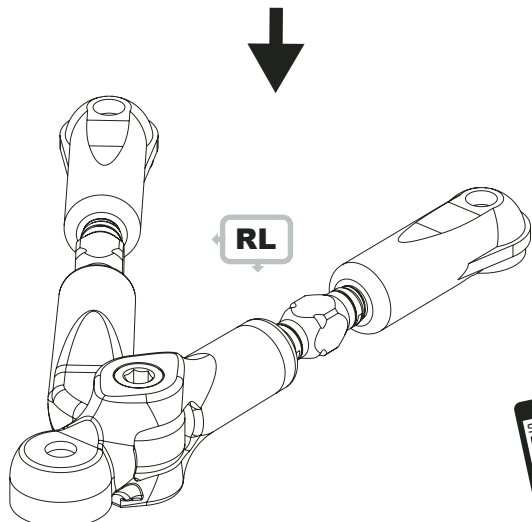
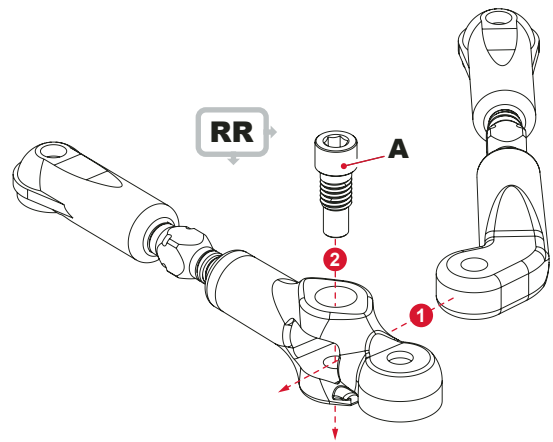
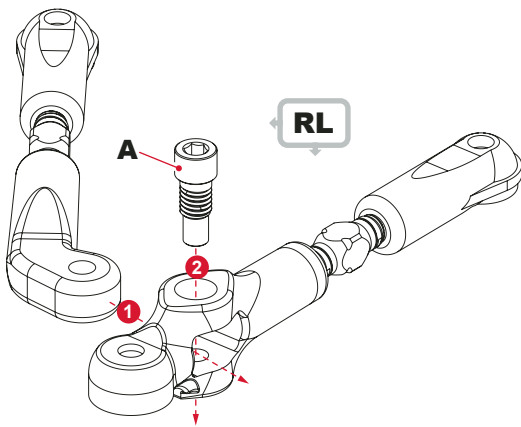
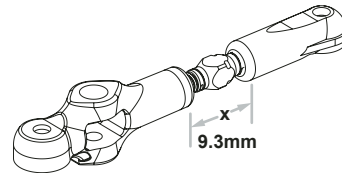

TRACK SETTINGS REFERENCE
Page 29

Upper Wishbone Fitting

BAG C - Step 16c

A x4

M3 Alloy Spacer 1.0mm



B x4

Short Ball Stud

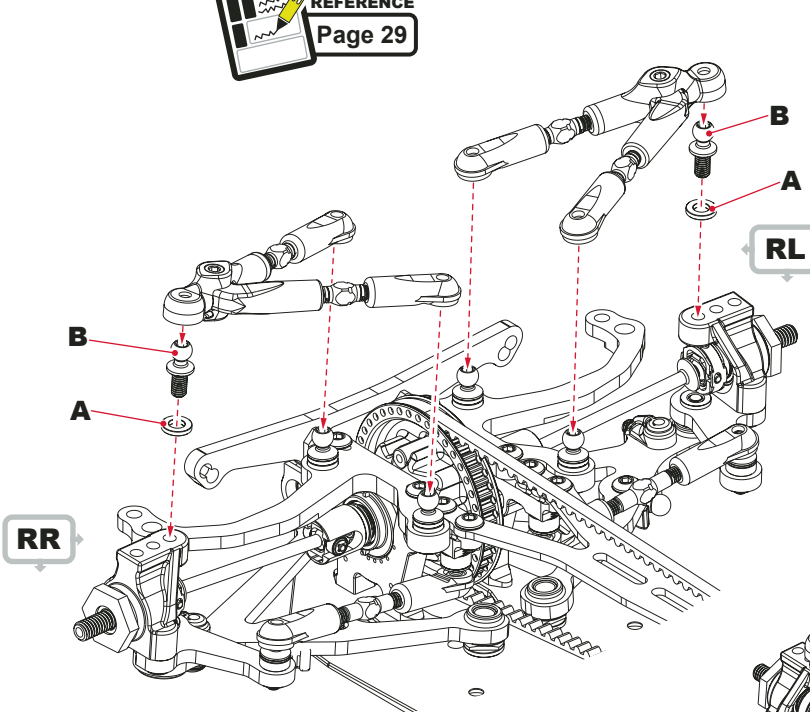
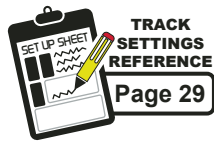
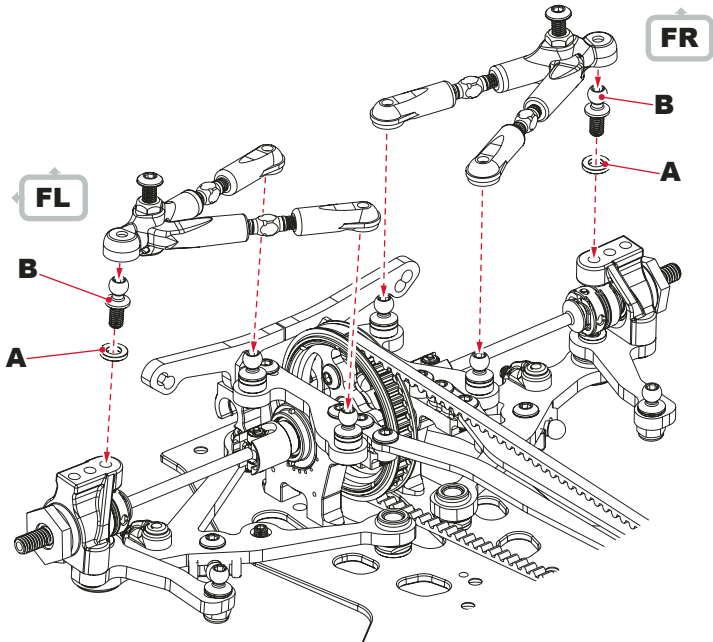

!
The ball sockets in this kit have been tuned to remove unwanted play. This causes some to be slightly tight. The perfect fit is to be very free, with no unwanted movement. To achieve the perfect fit, pull the ball stud against the socket, as shown. The socket does not need to pop off the ball in this process.

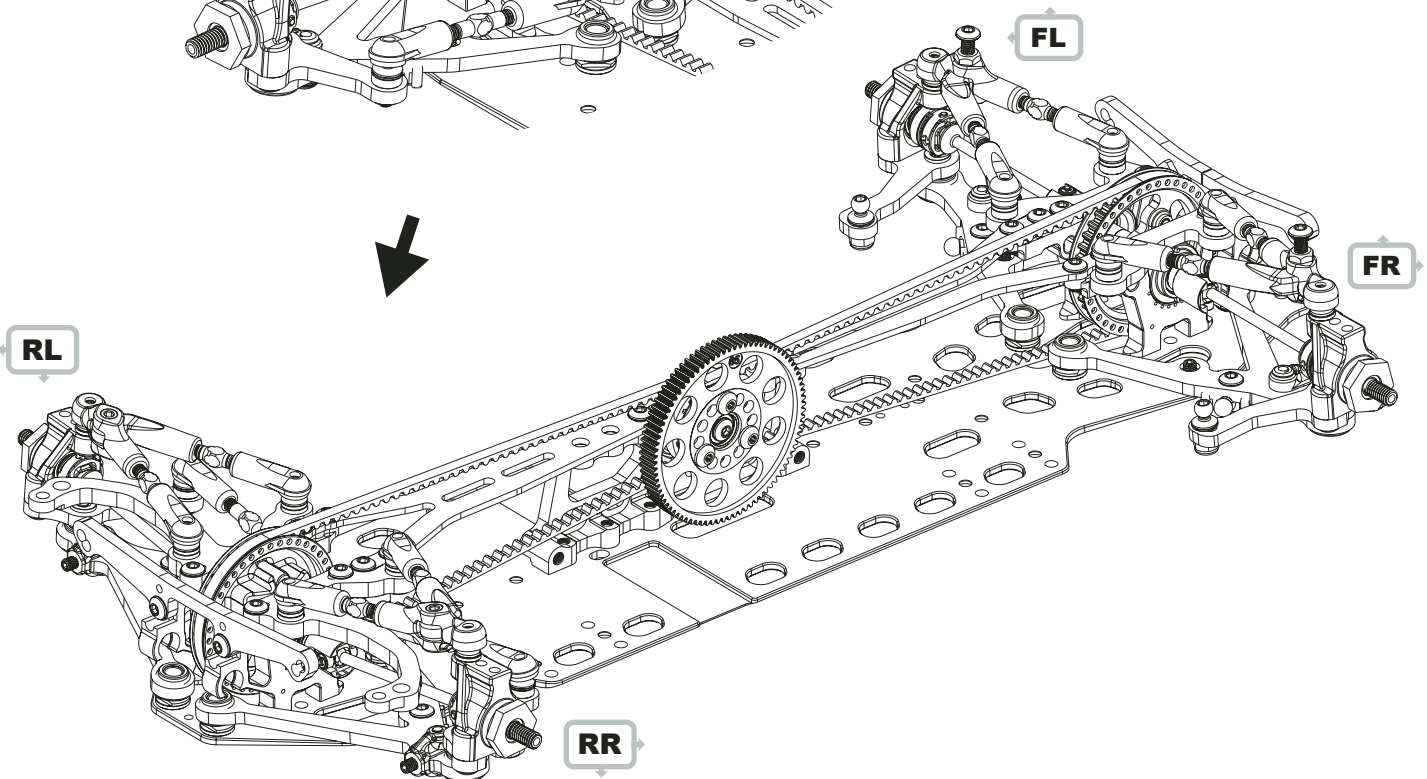

Centre Track Rod Assembly

BAG C - Step 17

A x2
M3 x 10 Csk Screw

B x2
Washer $\varnothing 3.0 \times \varnothing 4.5 \times 0.25$

C x2
M3 x 6 Grub Screw

D x1
Black (larger offset)
Ball Stud Ultra Short

E x2
(Smaller offset)
Low Ball Ultra Short

F x2
M3 x 4 Button Hd

G x2
Spacer $\varnothing 4 \times \varnothing 5.65 \times 1$

H x4
Bearing $\varnothing 4 \times \varnothing 8 \times 3$

I x2
M3 x 6 Csk Screw

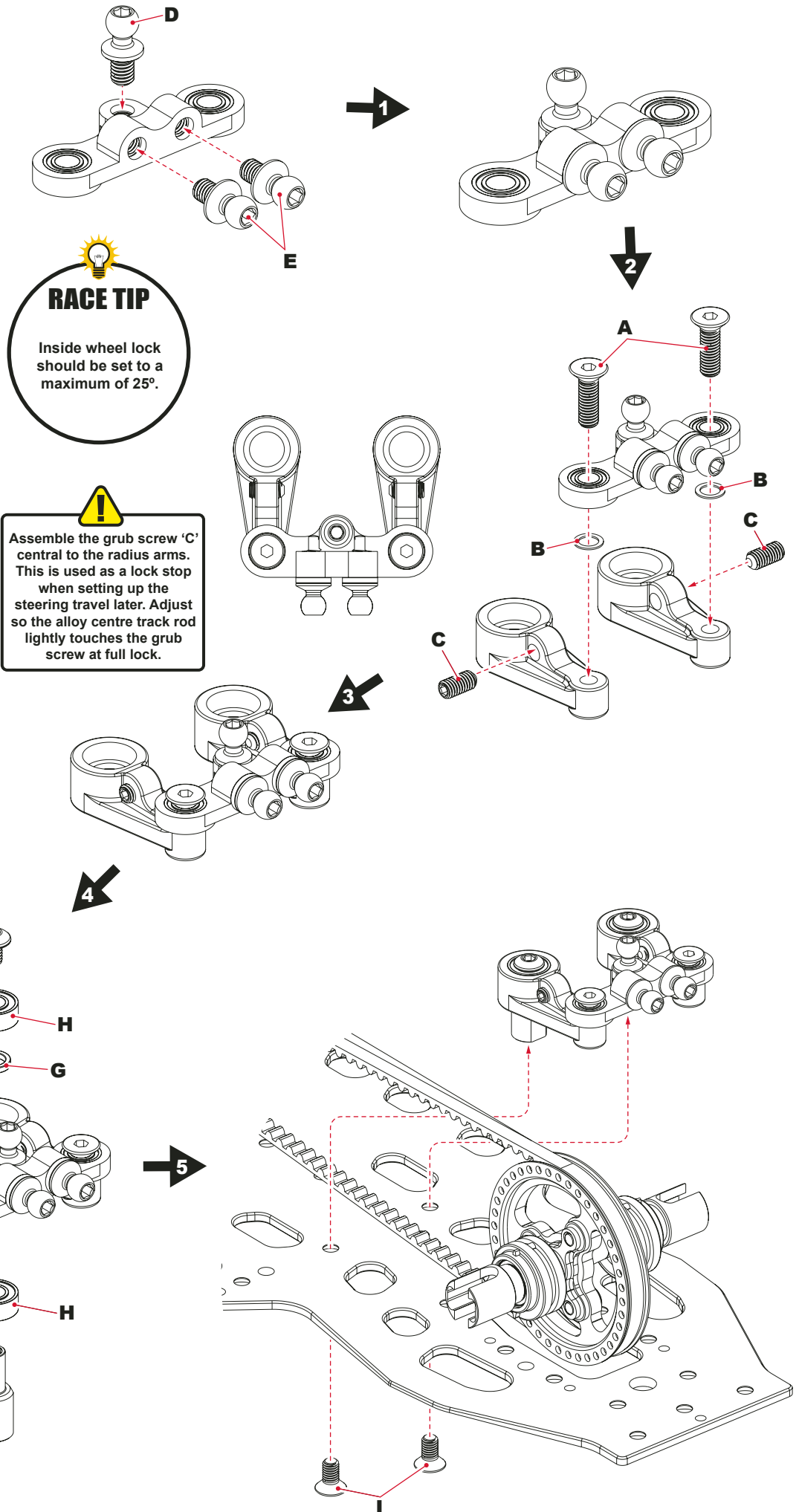

Steering Arm Fitting

BAG C - Step 17

Fit Front Links from Step 8a

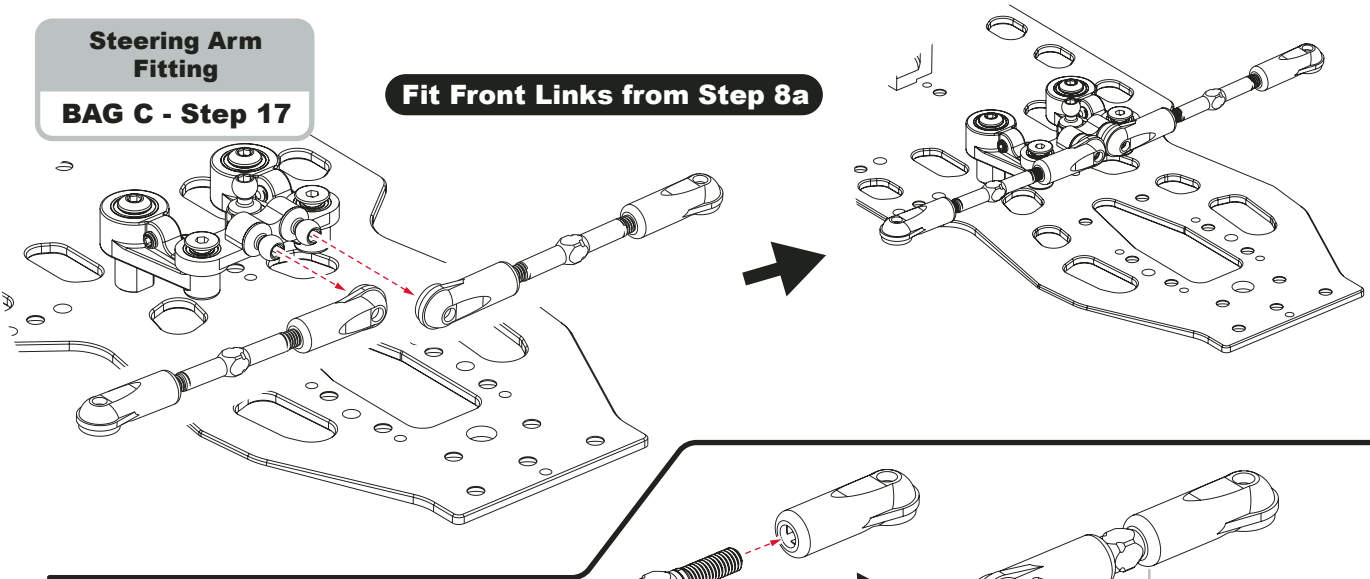

Steering Servo Installation

BAG C - Step 18

A x1

M3 x 8 Button Hd



B x1

Ball Stud Short

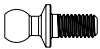

C x1

M3 Nut



D x3

M3 x 8 Csk Screw



E x3

M3 Black Alloy C/S Washer



F x2

M3 x 6 Csk Screw



Important: Select the correct horn for your brand of servo.



Sanwa KO



Futaba Core RC Highest Power HD Savox



The servo horn should be at approximately 15° when steering is central.

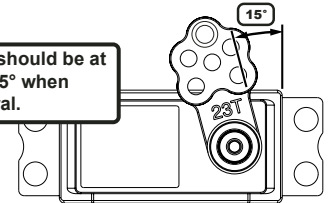

Before you assemble the servo horn, connect up your radio gear and set the steering servo to neutral.

Steering Servo NOT supplied.

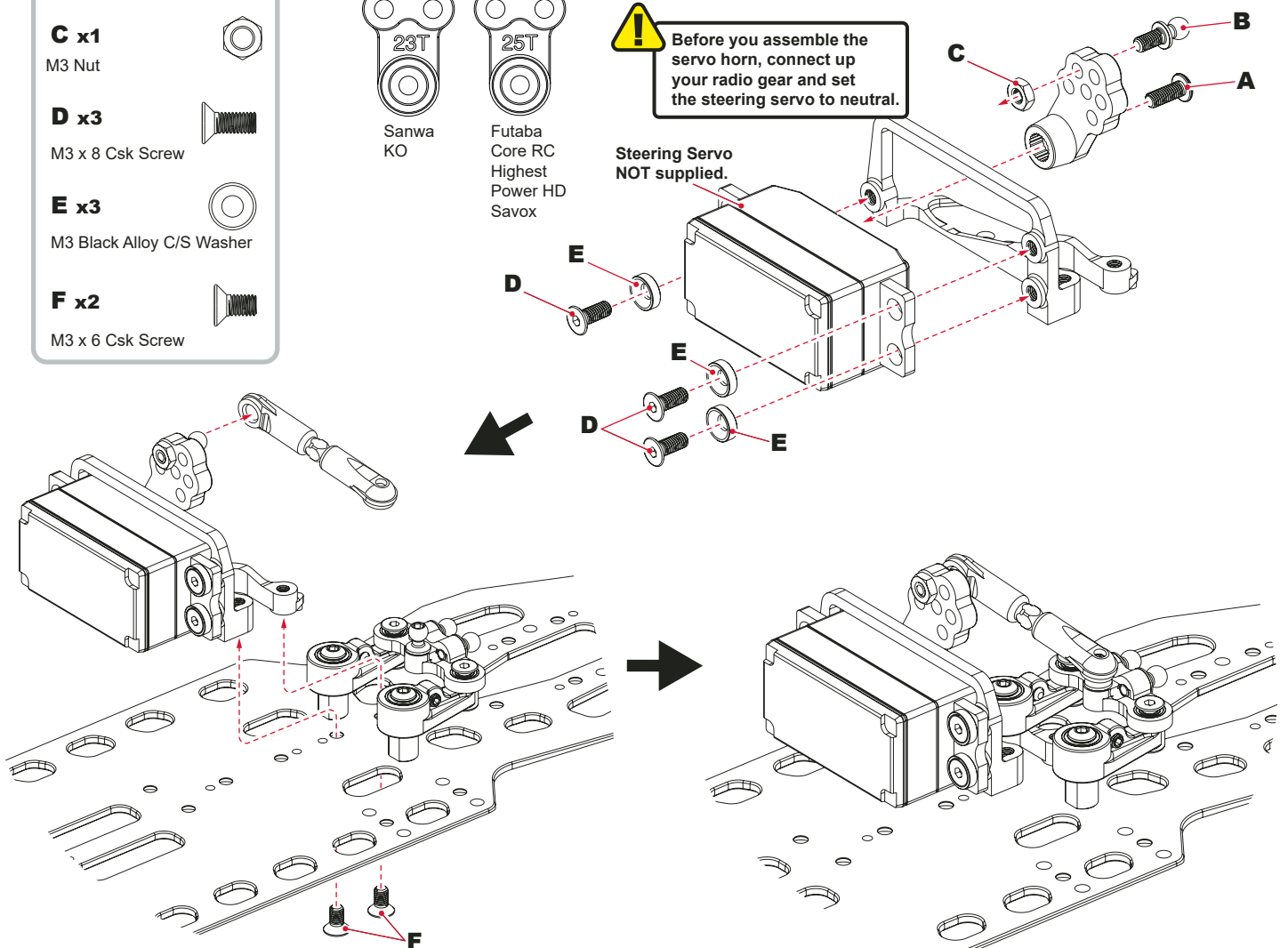

Front Anti-Roll Bar Fitting

BAG C - Step 19a

A x2
M3 x 3 Grub Screw

B x2
Bearing
ø1/8" x ø1/4"

C x2
M3 x 4 Grub Screw

!
Position the roll bar under the driveshafts before inserting the bearings into the transmission housings.

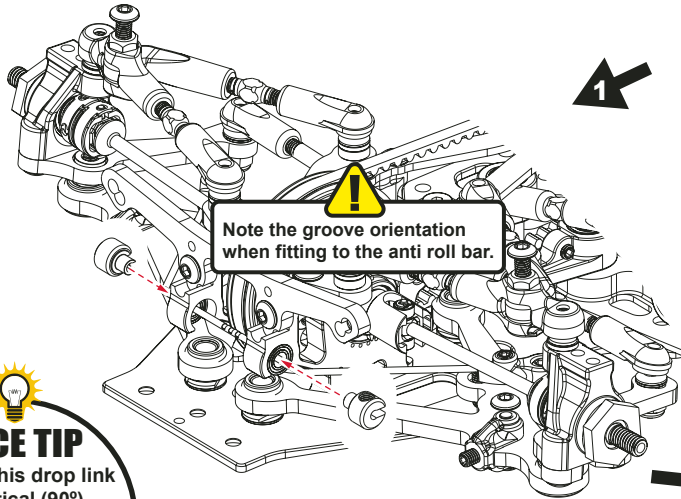
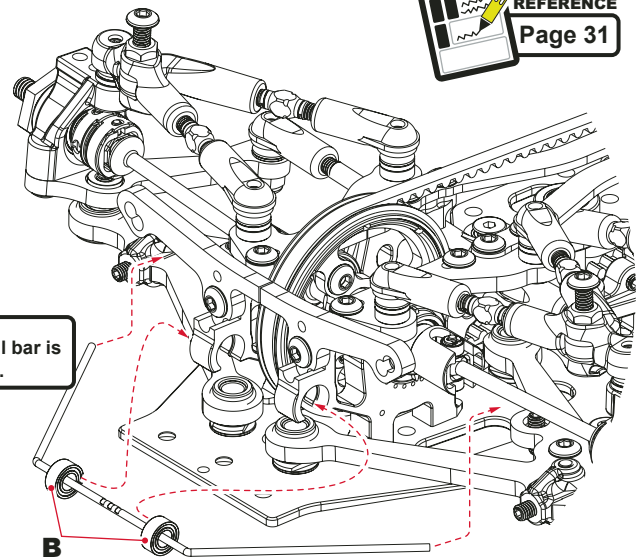

RACE TIP
Ensure this drop link is vertical (90°). The C/F steering should not hit the roll bar at full travel. See grub screws in step 17.

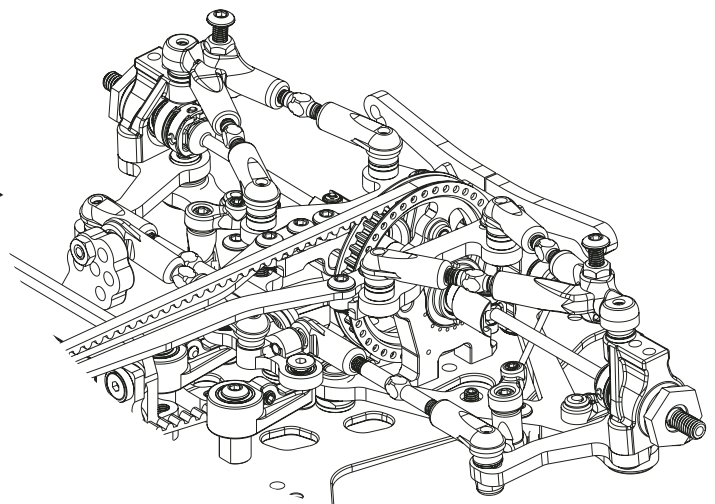
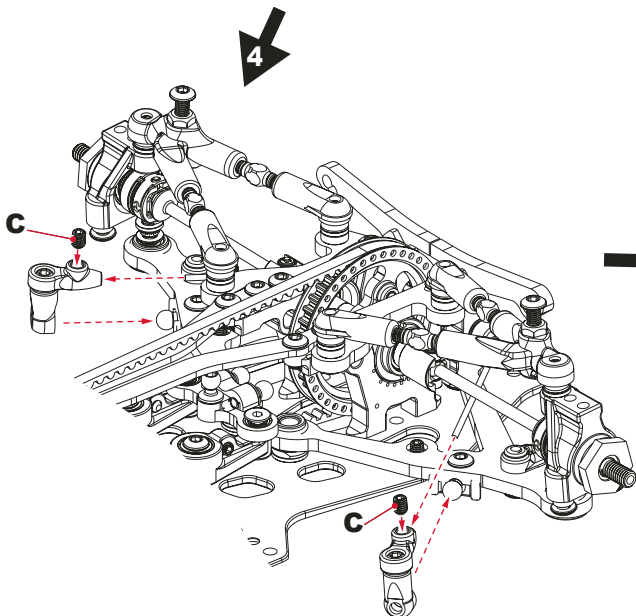
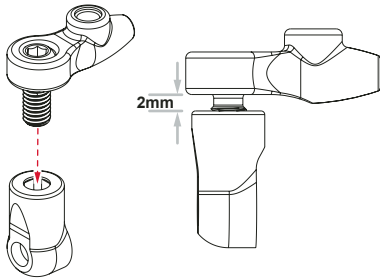
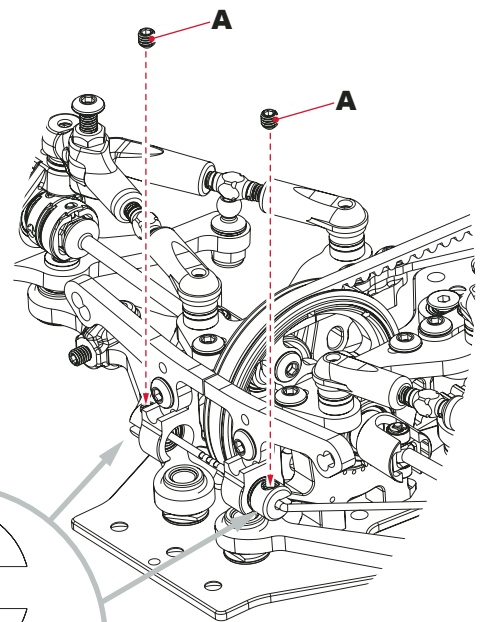

Rear Anti-Roll Bar Fitting

BAG C - Step 19b

A x2
M3 x 3 Grub Screw

B x2
Bearing
ø1/8" x ø1/4"

C x2
M3 x 4 Grub Screw

!
Position the roll bar under the driveshafts before inserting the bearings into the transmission housings.

!
The kit rear roll bar is 1.2mm (2 lines).

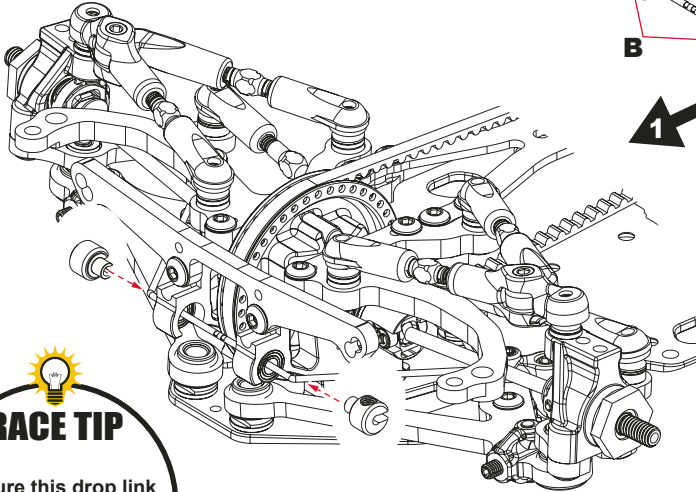
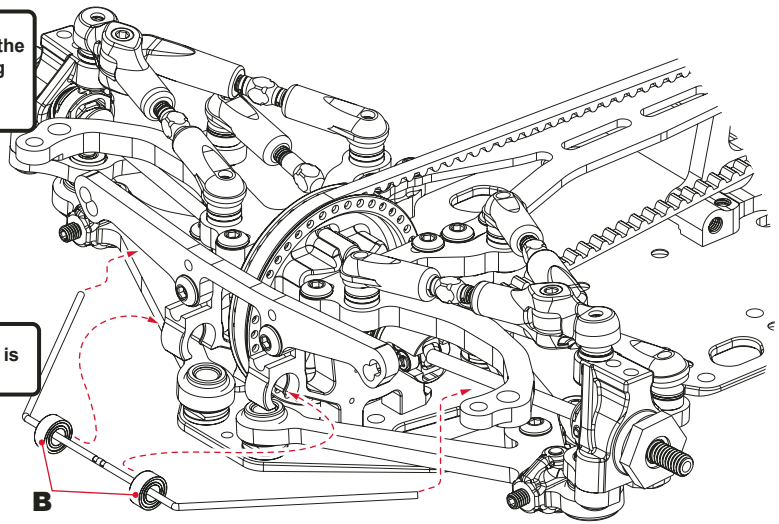

RACE TIP
Ensure this drop link is vertical (90°).

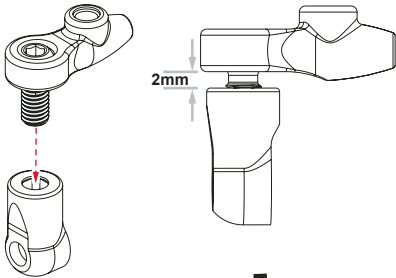
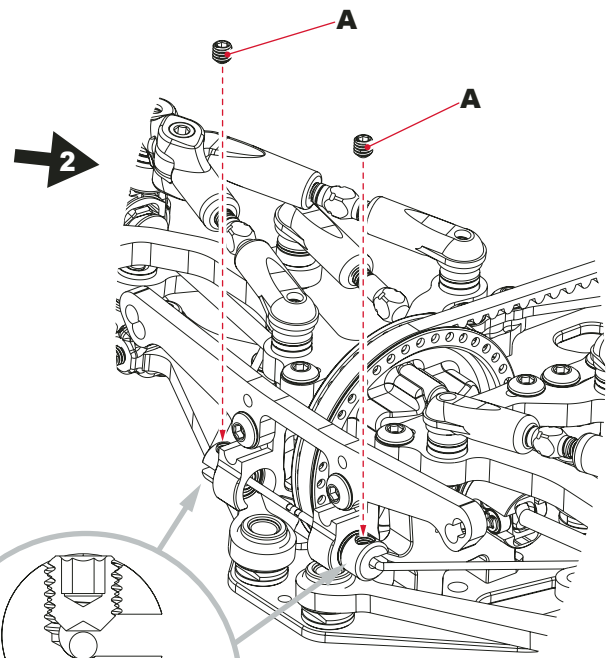

!
Make sure the roll bars are positioned in the centre of the clamps, after the grub screws **A** are tightened.

TRACK SETTINGS REFERENCE
Page 31

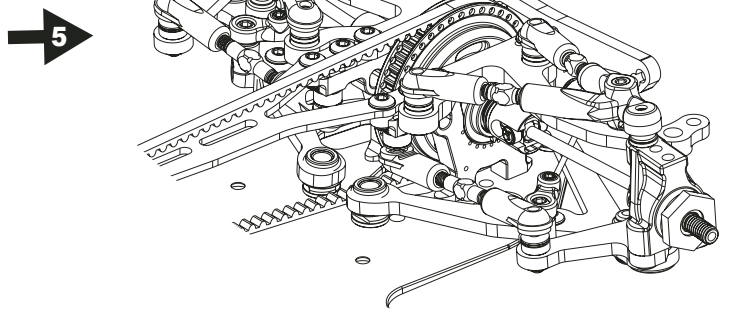
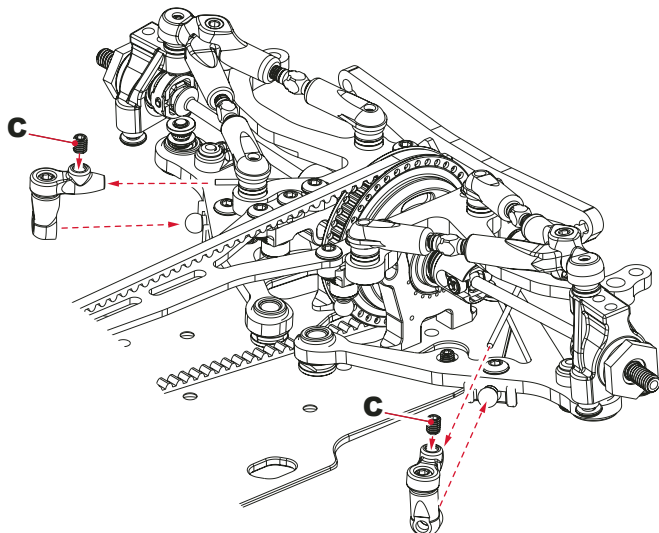

Shock Absorber Assembly

BAG C - Step 20

- A x8**
Shim 0.05
- B x4**
M2 x 6 Csk Screw
- C x4**
Red 'O' Ring
- D x4**
'O'ring $\phi 13 \times 1.0$

!
For better sealing add shims **A**.
For less friction remove them.
We suggest to start with 2.

!
The factory setting
has 2 shims here.



RACE TIP
Building the shocks, filled with oil will allow the 'O' rings **C** to expand slightly. This creates a perfect fit. If you have time, build the shocks, leave to stand for several hours, then build again before use. Do not leave 'O' rings submerged in oil.

!
Build 4.

!
Ensure screw is clean & let threadlock dry for 20 minutes before filling shocks with oil.

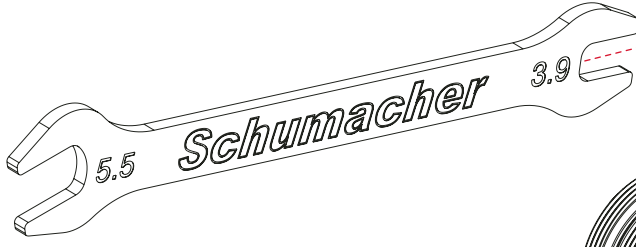

!
Build 4.

!
Fill with shock oil up to this line. The kit setup is 400cSt in all shocks.

TRACK SETTINGS REFERENCE
Page 33

!
Slowly move piston up and down 2 or 3 times. Then wait for the air bubbles rise to the top and disappear. This may take up to 5 minutes.

!
The rebound can be changed by adjusting the distance 'x' before fitting the diaphragm and top ring.

!
Build 4.

Shock Absorber Installation

BAG C - Step 21

A x4
M3 x 8 Button Hd Screw

B x4
Lower Shock Ball

IMPORTANT:
Align spring seat with
the pip on the socket.

FRONT - Use Orange Springs

REAR - Use Black Springs

**Use the screw A to 'snap'
the ball into place.**

IMPORTANT:
Insert the ball from
the correct direction.

**Use a M3 washer
from earlier steps.**









REAR - Use Black Springs

SET UP SHEET
TRACK SETTINGS REFERENCE
Pages 29 & 30



Battery Holder Installation

BAG C - Step 22

- A x2**  M3 Alloy Spacer 0.5mm
- B x2**  Grey 0.5 mm
- C x4**  M3 x 12 Button Hd
- D x2**  M3 x 16 Button Hd
- E x4**  M3 Alloy Spacer 3.0mm
- F x2**  M3 x 10 Csk Screw
- G x2**  M3 x 12 Csk Screw
- H x2**  M3 x 10 Button Hd

! Three different plastic LiPo spacer pairs are included: ULCG LiPos: 1.5mm (using 10mm Button Hd Screws **H**) LCG LiPos: 3.5mm (using 12mm Button Hd Screws **C**) Full height Lipos: 6.5mm (using 16mm Button Hd Screws **D**).

! Adjust the screws **F** to set the front to rear position of the LiPo. Ensure there is always approximately 0.5mm of endfloat. This will help flexibility. The kit LiPo position is central.

💡 RACE TIP
Adjust the LiPo holder to allow approximately 0.5mm end float in all directions. This will help chassis flexibility.

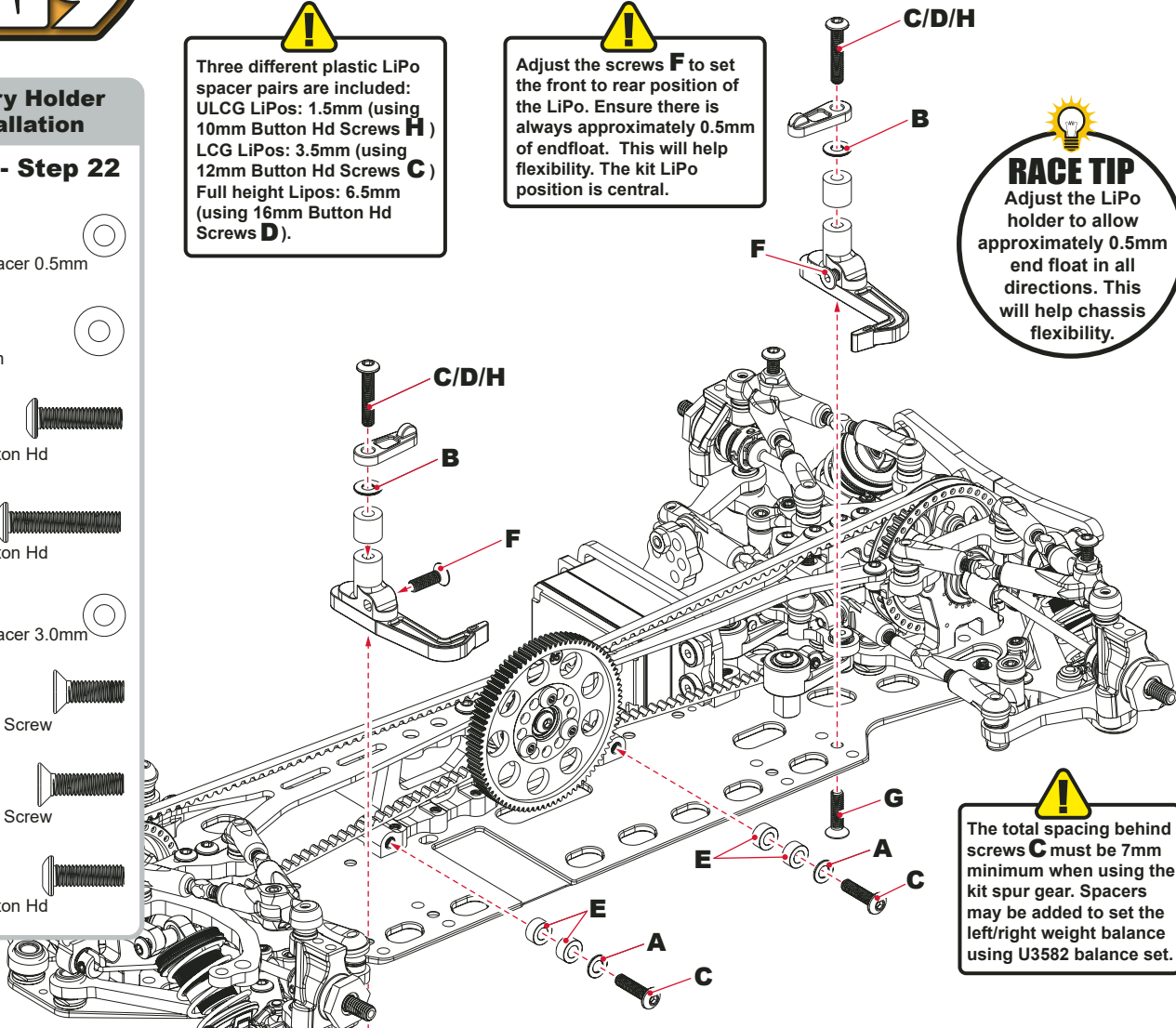



! The total spacing behind screws **C** must be 7mm minimum when using the kit spur gear. Spacers may be added to set the left/right weight balance using U3582 balance set.

! Loosen screws **G** to set the hook position.

Front Bumper Assembly

BAG C - Step 23a

- A x2**  Pin ø1.5 X 11.8
- B x2**  M3 x 10 Button Hd
- C x2**  M3 x 12 Button Hd

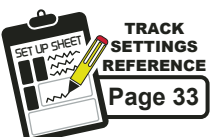

! The body hangers adjust the height of the body in 1.2mm steps. Note the dots on the underside.

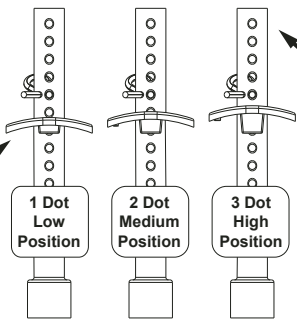

! The bodyposts can be trimmed down for looks and aerodynamics. Use a sharp knife or side cutters. Alternatively use: AM190041 Body Post Trimmer.

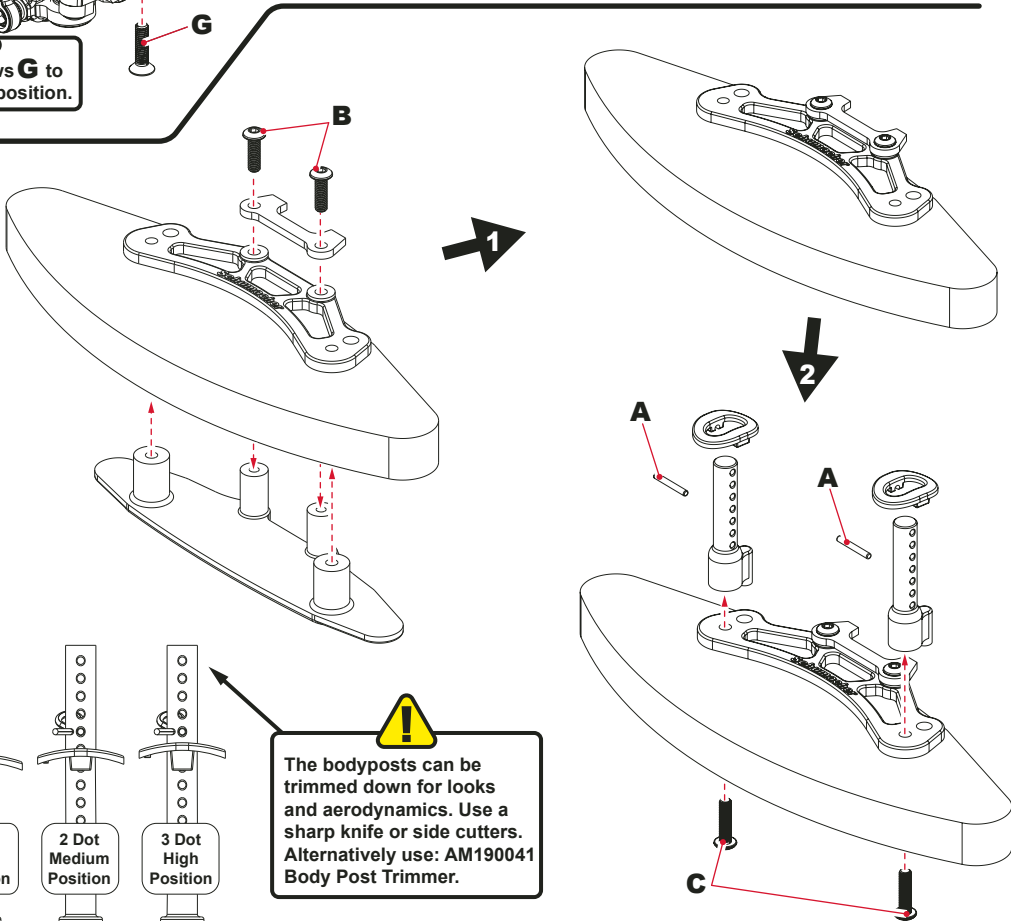

Bumper Installation

BAG C - Step 23b

A x2



M3 x 10 Csk Screw

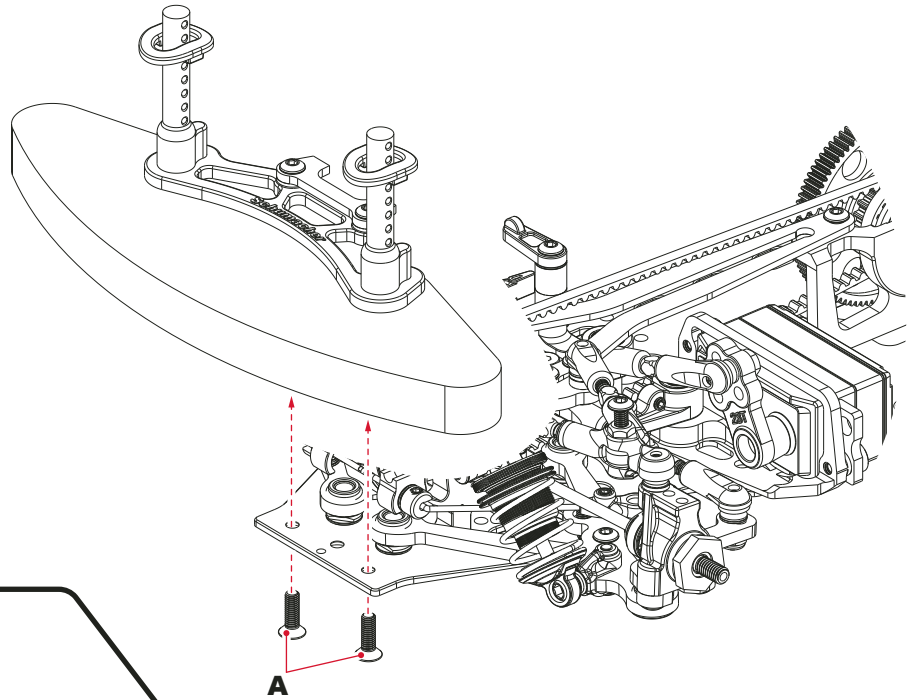

Rear Body Post Installation

BAG C - Step 23c

A x2

Pin $\varnothing 1.5 \times 11.8$

B x2

M3 x 10 Button Hd

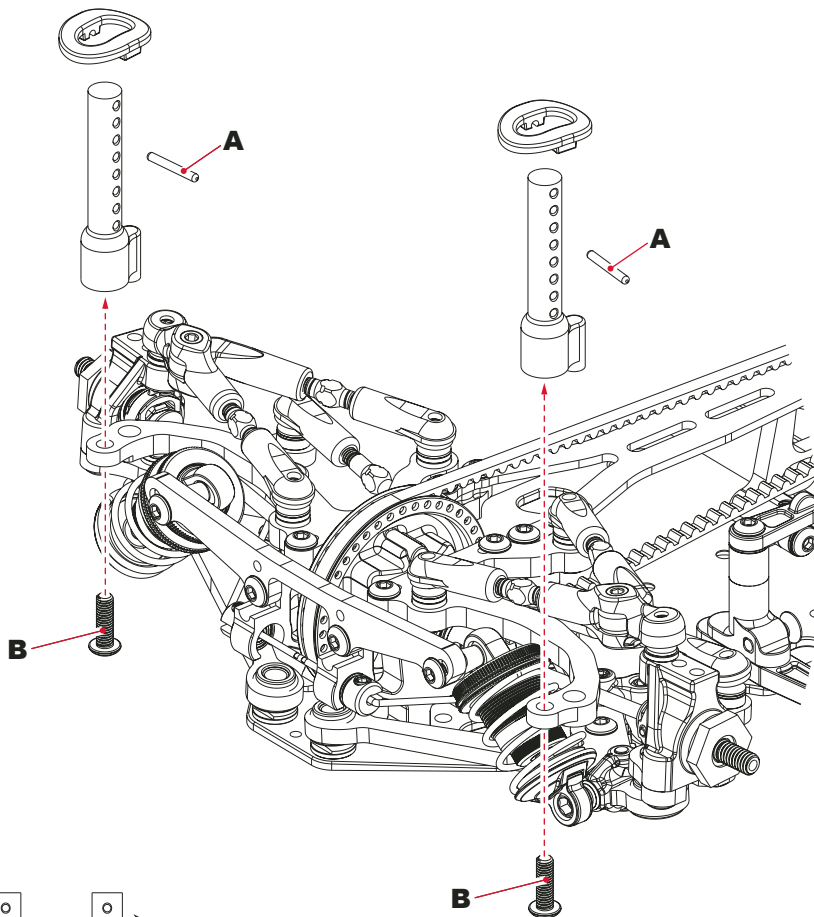
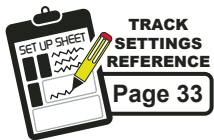

The body hangers adjust the height of the body in 1.2mm steps. Note the dots on the underside.

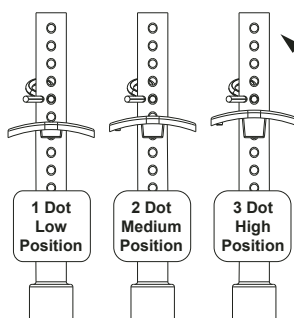

The bodyposts can be trimmed down for looks and aerodynamics. Use a sharp knife or side cutters. Alternatively use: AM190041 Body Post Trimmer.

Motor Installation

BAG C - Step 24a

A x2

M3 x 8 Button Hd

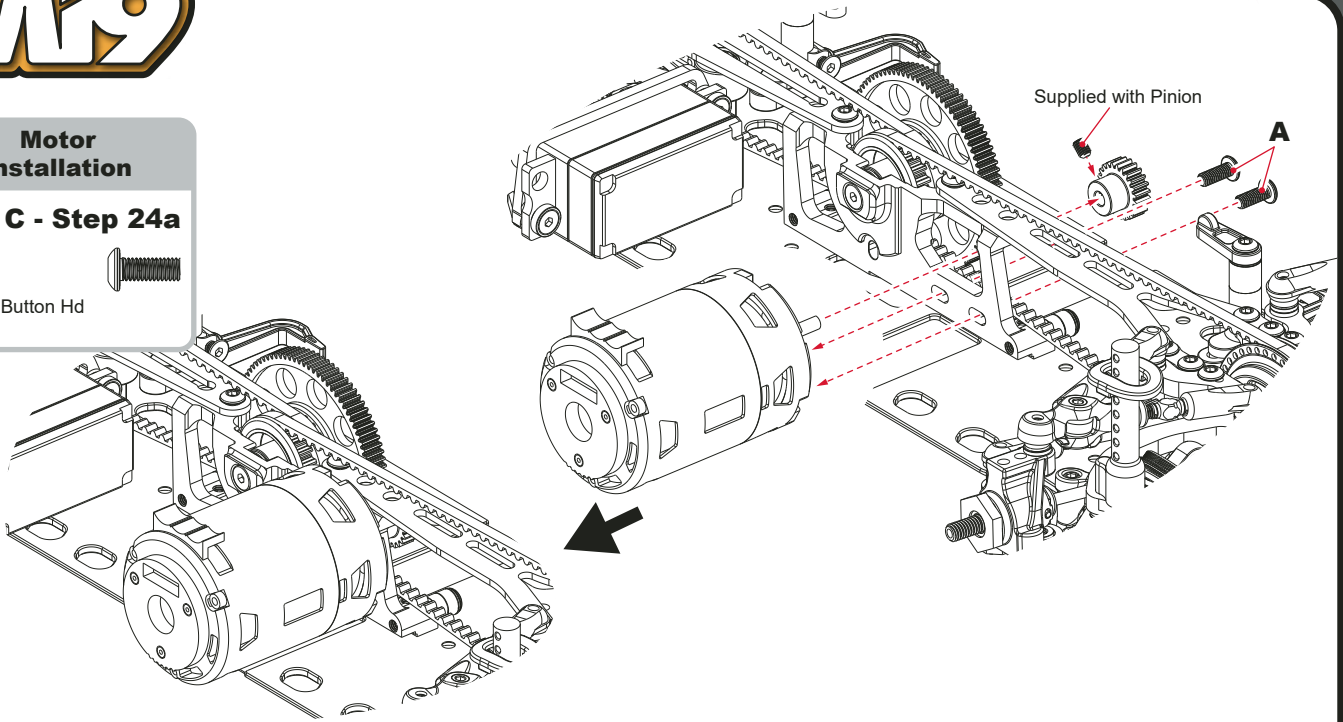

Electronics Installation

BAG C - Step 24b

A x1

M3 x 4 Cup Point Grub Screw



B x1

M3 x 6 Csk Hd Screw

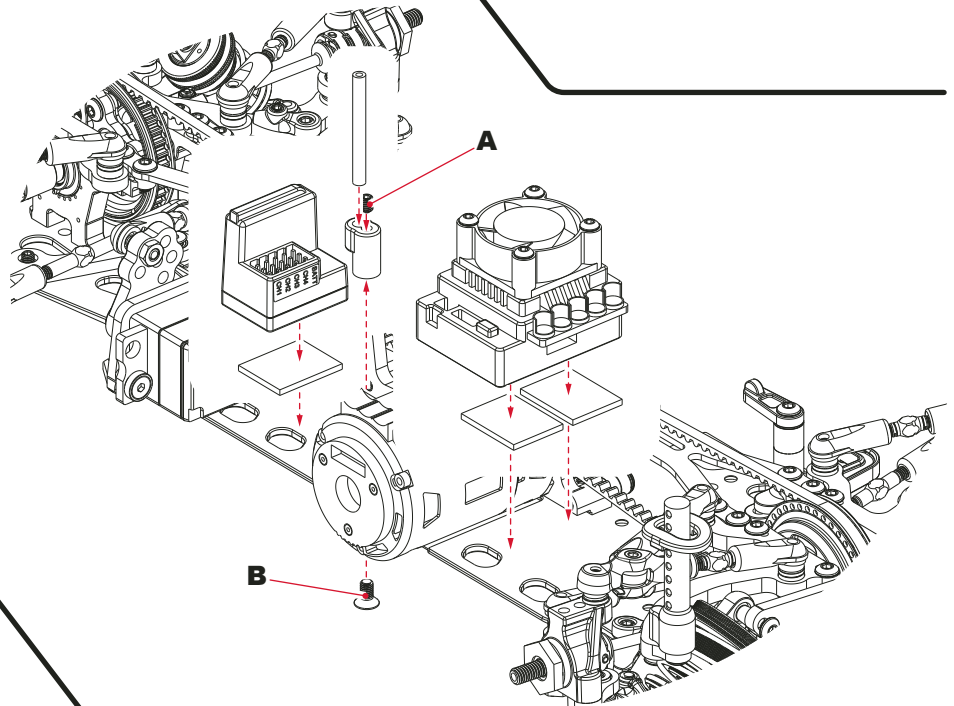

Lipo Installation

BAG C - Step 24c

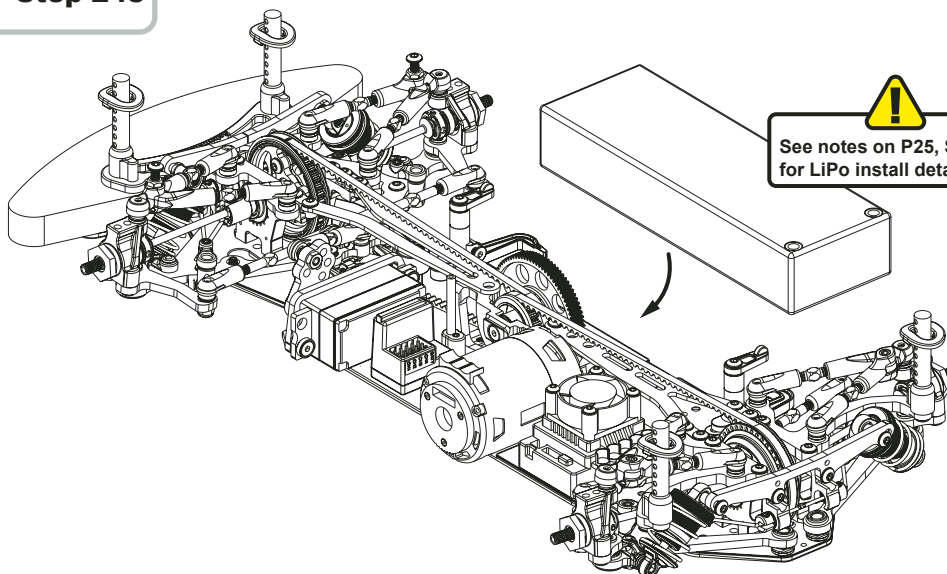

See notes on P25, Step 22 for LiPo install details.

Tyres & Wheels Installation

BAG C - Step 24d

A x4
Body Clip

B x4
M4 Serrated Nut

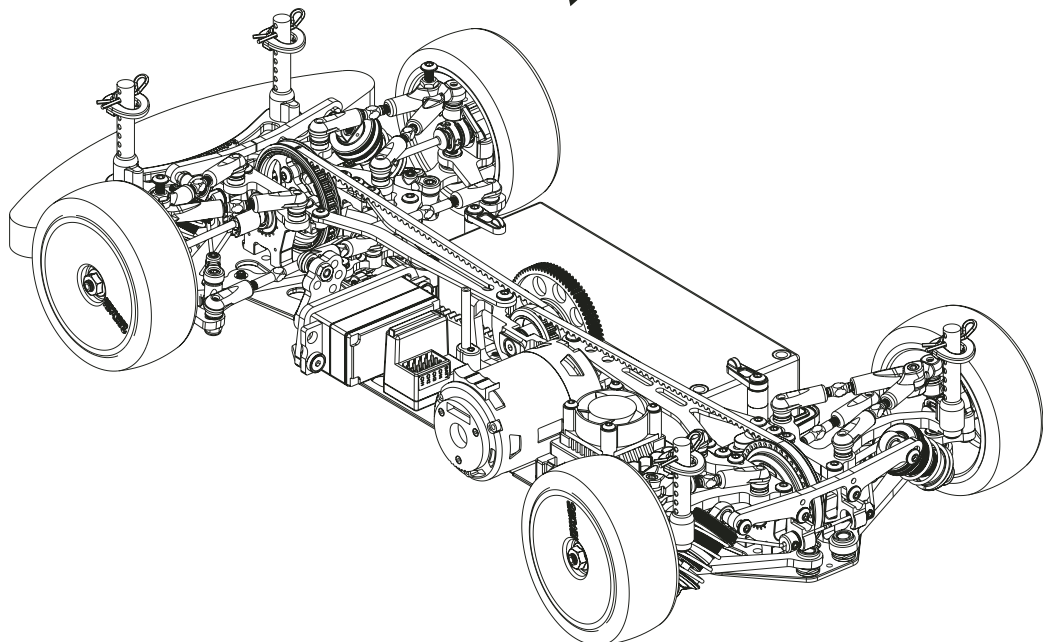
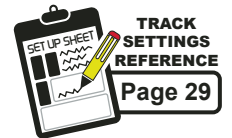
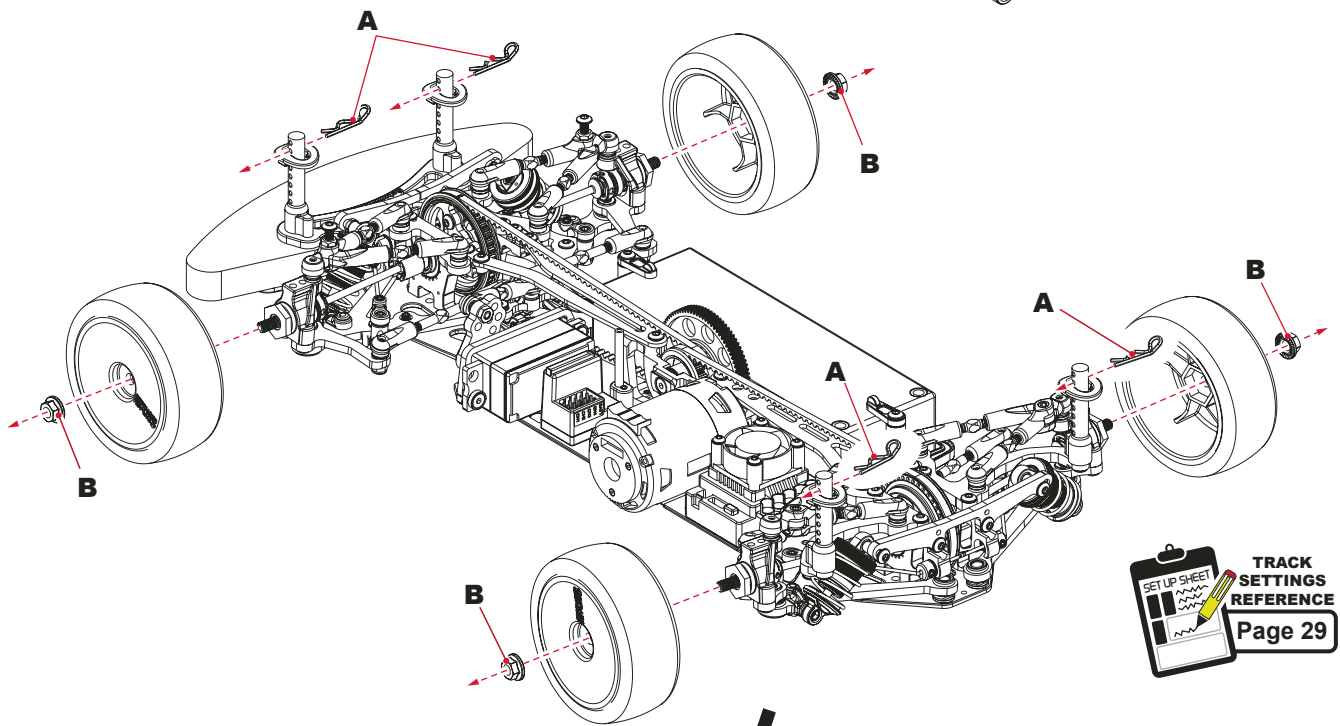
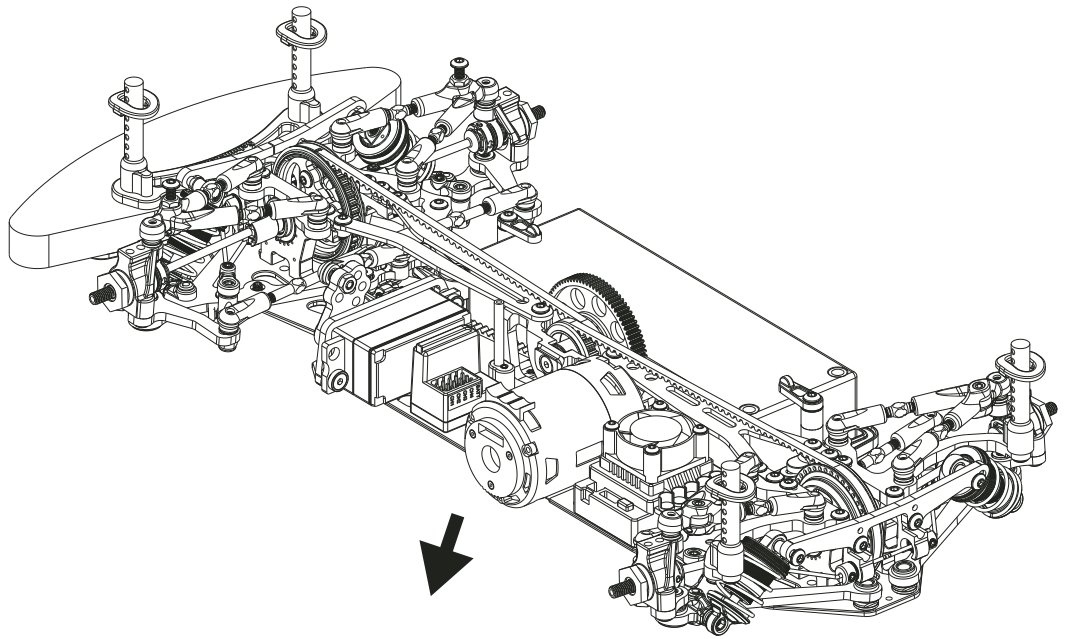



TRACK SETTINGS

RIDE HEIGHT

See Page 24 Step 21

Use the spring adjusters on the shock absorbers to adjust the front and rear ride heights. We recommend setting the ride height to around 5.0mm on carpet/ high traction tarmac/asphalt and 5.5mm on tarmac/asphalt or low traction carpet tracks.

This is measured between the bottom of the chassis and the ground with the car in running trim. First press the car down on to the ground and release it once or twice to settle the suspension before adjusting the ride height.

In general:

High traction levels/Smooth tracks = Lower ride height (4.6mm-5.2mm)

Low traction levels/Bumpy tracks = Higher ride height (5.2mm-6.0mm).

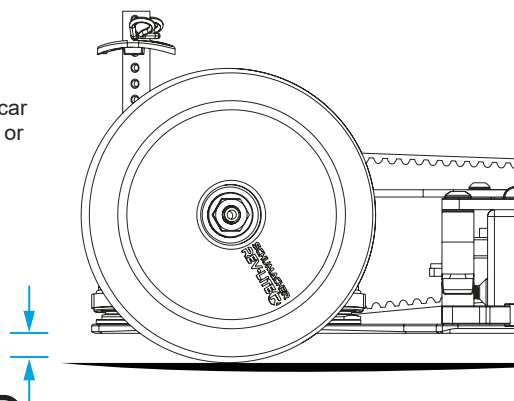

CAMBER

See Pages 16 & 17 Steps 16a & 16b

Front and rear camber is set by adjusting the pair of upper turnbuckles:

Shorter turnbuckles= More Negative camber.

Longer turnbuckles= Less Negative camber.

**The Camber and Castor setting should be set using a setup system such as SK-600069-01 or AM171040-LE combined with castor pointers U8771

In general the aim is to run the correct amount of camber for the tyre being used and the track conditions. Typically this is between 1.0°-2.5°.

Increasing the front and rear camber together will often result in more traction, but with a more sudden loss of grip when going beyond the limit. Less overall camber will offer a more progressive slide but may have less overall grip.

More castor may be applied to the front or rear, normally resulting in more grip at that end of the car. The team suggest a starting camber of 2° Rear and 1.5° Front, increasing to 2° Front camber if more front grip/steering is needed.

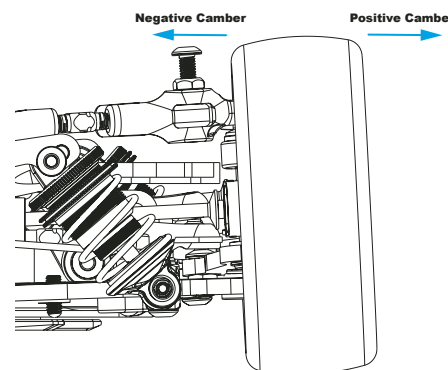

CASTOR

See Pages 16 & 17 Steps 16a & 16b

Castor can be set by adjusting the upper turnbuckles. After camber has been set, lengthen one turnbuckle, and shorten the other by the same amount, until the castor is set as desired.

**The Camber and Castor setting should be set using a setup system such as SK-600069-01 or AM171040-LE combined with castor pointers U8771

More front castor will result in a smoother, less responsive initial steering response, with more mid corner/ on power exit steering.

Less front castor will give a more aggressive initial steering response but less steering thereafter. Kit setting is 4°.

Rear 'castor' can be adjusted, altering the wheelbase. Kit setting is 4°

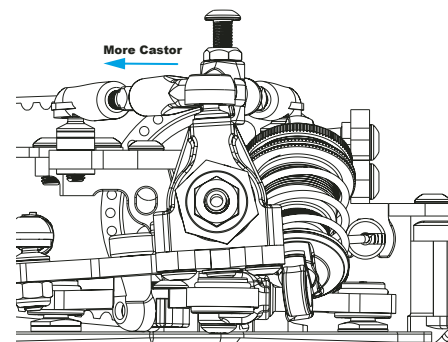

TRACK WIDTH

See Pages 14, 15 & 28 Steps 14, 15 & 24d

The track width may be adjusted using 2 different hex widths, or shims:

U8333 - Wheel Hex Spacers 0.25, 0.5, 0.75mm - (pk12)

U8720 - Alloy Wheel Hex - Mi9 (pr)

U8762 - Alloy Narrow Wheel Hex (-0.75mm) - Mi9 (pr)

Increasing the rear track width provides more rear stability/less rotation and vice versa.

Increasing the front track width provides a less aggressive/less rotation and vice versa.

A wider car is better suited to high traction conditions and a narrower car to low traction conditions.

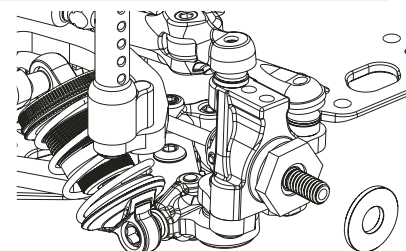

STATIC REAR TOE

See Page 11 Step 8b

Static rear toe is measured on setup gauges such as SK-600069-01 or AM171040-LE and is the toe angle of the rear wheels when at ride height. The kit setup is 3°.

This is adjusted simply by altering the length of the rear turnbuckles shown. More rear static toe in provides more stability, rear grip and forward traction. Less rear static toe in offers more rotation providing the rear stability is enough to drive confidently through the corner. There will be less forward traction exiting the corner however.

In low traction conditions the team suggests a range between 3° and 4°. In high traction conditions the team suggests a range between 2° and 3°.

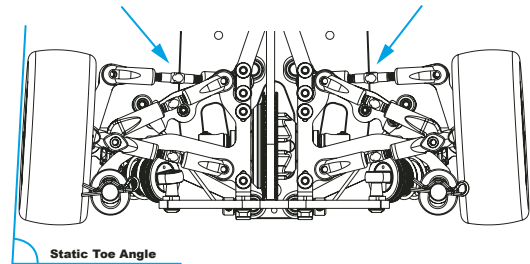

Static Toe Angle

DYNAMIC REAR TOE

See Page 15 Step 15

Dynamic rear toe is a toe in angle that changes with roll or squat. This allows for a rising rate toe setting through a corner providing good entry steering but with more stability through the corner and more forward traction on corner exit. The roll centre or rear castor setup affects passive toe gain a specific spacer provides. 1mm gives approximately static toe in most common car setups.

The team recommend:

- 1mm in high traction conditions or when a lot of steering is needed.
- 4.5mm in low traction conditions or when a lot of stability is needed.

Kit setup is 2.5mm, a good neutral point.

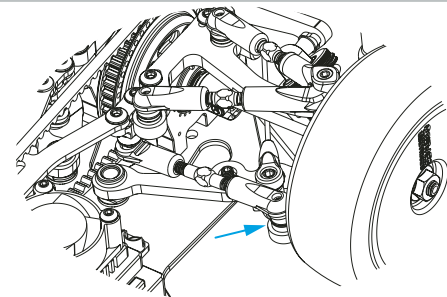

FRONT TOE

See Page 20 Step 17

The front toe is set by adjusting the steering turnbuckles.

Toe in will give a more stable car and less responsive/nervous initial steering.

Toe out will give a more aggressive car with more responsive initial steering.

The team recommend a range between 0° and 1° of toe out. It is very rare to benefit from toe in on the front of the car.

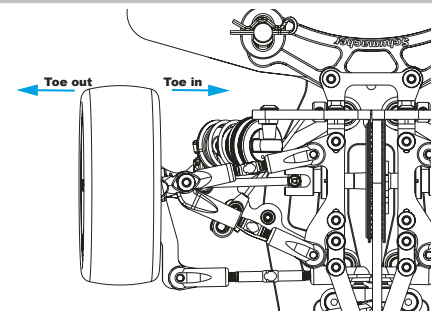

SHOCK SPRINGS

See Page 24 Step 21

Shock springs are used to set the suspension stiffness.

The team recommend a starting setup using CORE RC Orange springs at the front and Black at the rear (included).

Stiffer springs increase response, forward traction and high speed stability. The track should be smooth when going to very stiff springs.

Softer springs slow down direction change but may provide more overall grip, when the track grip is low. They may cause high speed stability issues if the grip is too high. Soft springs can be better when the track is bumpy. A softer car can sometimes be a benefit in very high grip, in order to prevent traction roll.

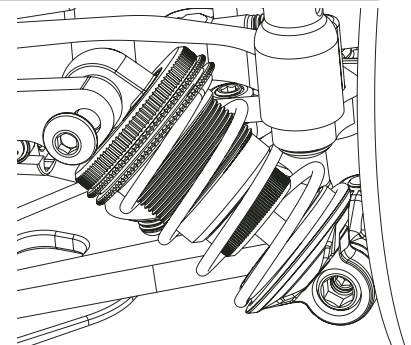

SHOCK ANGLES

See Page 24 Step 21

Similar to the shock spring setup, the shock angles can provide fine tuning over the suspension stiffness.

A more angled shock setup (lower number shock mount holes) creates a softer setup which is less responsive, often suited to high traction conditions.

A more upright shock setup (higher number shock mount holes) creates a stiffer setup which is more responsive, often suited to lower traction conditions.

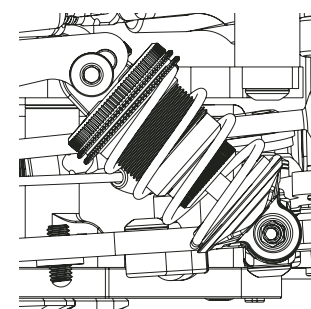

ANTI ROLL BARS

See Pages 21 & 22 Steps 19a & 19b

Anti roll bars allow the tuning of roll stiffness and change the way that the weight is transferred.

A stiffer rear roll bar will reduce entry steering but increase on power steering.

A stiffer front roll bar will increase entry steering, but provide a smoother handling through the middle of the corner.

The roll bars need to be set equally left to right. This is done by adjusting the drop link ball height. With the shocks off, check the roll bar lifts the opposite side when lifted to an equal height. A great tool for this is AX015.

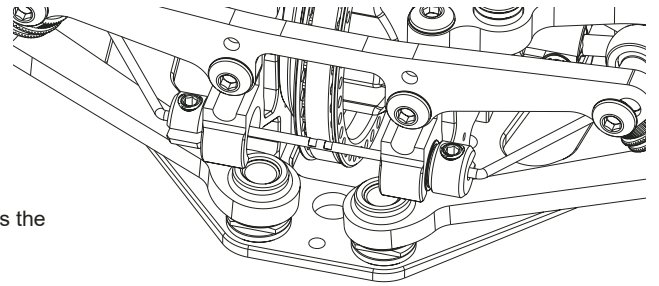

DROOP

See Pages 11 & 12 Steps 9 & 10

The starting point for droop suggested by the team is 22.6mm rear, 23.8mm front. These numbers are checked on the Aerox droop gauge set. AX015. This is the measurement between the chassis underside and the axle centre. Droop is adjusted using the grub screw illustrated.

The suggested range is:

Rear- Between 20.4mm in low traction and 24.0mm in high traction. Increasing the rear droop often provides more stability.

Front- Between 21.4mm in low traction and 25mm in high traction. Increasing the front droop gives a more aggressive handling.

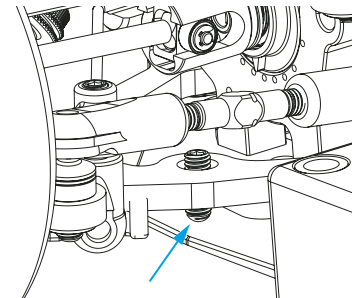

UPPER INNER LINK HEIGHT

See Page 9 Step 7a

The washers under the 4 upper inner link ball studs are the main suggested method of changing the angle of the upper links. We recommend keeping the outer ball stud spacing around 1mm to ensure good thread engagement into the plastic hub carriers. Generally, less washers at that end of the car gives more grip. Adding washers in the front/rear together can provide a freer car with more rotation. Suited best to high traction.

NOTE: The high transmission housings (U8729) will increase the height of the ball studs by 2mm. Make sure to take this into consideration when changing between 'high' and 'low' transmission housings.

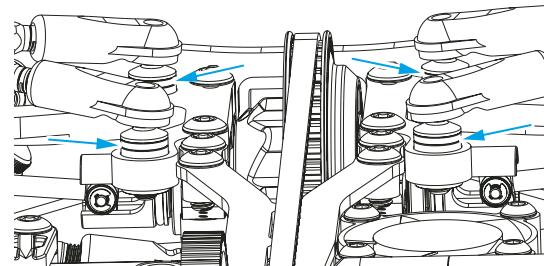

LOWER WISHBONE SPACERS

See Page 12 Step 11

Higher wishbone balls= Raised roll centre, suited to higher traction conditions.
Lower wishbone balls= Lower roll centre, suited to lower traction conditions.

The team often uses wishbone balls 0.5mm lower in the front than the rear, providing more steering, but a slightly more difficult car to drive.

Lowering the front-front balls (angling the front wishbones down to the front of the car), by 0.5mm (the kit setting) is another team favourite. This creates some anti-dive, giving a much smoother steering, particularly on corner entry.

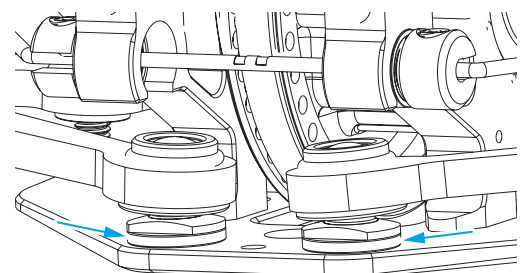

GEAR DIFF

See Page 4 Step 3

Gear diff oil can be changed to affect car handling.

Generally, high traction conditions = thicker oil. (7k-12k)

Low traction conditions = thinner oil. (3K-7K),

A thicker gear diff oil will have a much smoother off power, corner entry feeling, preventing corner entry over rotation. It will also make the car feel less likely to slide off power, in the corner. It will however have more on power steering, and can feel like on power oversteer.

Thinner gear diff oil will create the opposite effect. More aggressive corner entry, and more steering off power in the corner. It will have less on power steering, but will feel much easier to put the power on without oversteering.

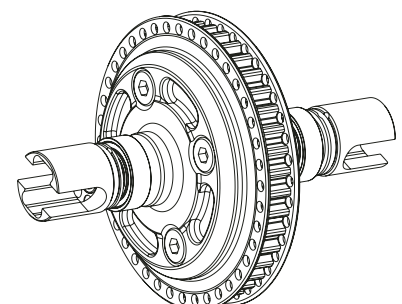

CHASSIS FLEXIBILITY

See Page 2 Step 1

High grip conditions=Stiffer chassis setup. Low Grip conditions = Flexible chassis setup.

The Alloy chassis is the stiffest option and is best in very high grip conditions. The CF chassis is best in low or medium grip conditions. It will generate more traction.

The motor mount has 4 chassis screw options. Use more screws to increase the overall chassis stiffness. A minimum of 2 screws is required.

U8256 Alloy T Brace increases rear chassis stiffness and creates more rotation and is intended for high grip conditions.

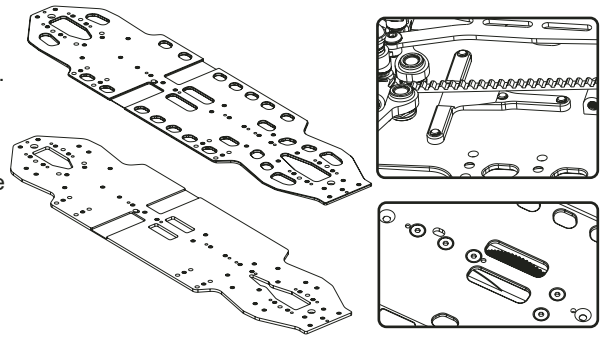

DIFF/SPOOL HEIGHT

See Pages 5 & 6 Steps 3 & 4

The Diff/Spool height can be adjusted in two ways.

- The eccentric housings can be rotated 180° to offer a 1mm shift in diff height.
- The Optional 'High' Transmission housings can be used to increase the Diff/Spool height by 2mm.

The low diff or spool position provides more grip at that end of the car, and is suited to low or medium traction conditions.

Diff Height	Eccentric Orientation	Eccentric Type	Transmission Housing Type
2.0mm	Up ▲	+0.5mm (Option U8777)	High (Option U8729)
1.5mm	Up ▲	Kit	High (Option U8729)
0.5mm	Down ▼	Kit	High (Option U8729)
0.0mm	Down ▼ / Up ▲	+0.5mm (Option U8777)	High (Option U8729) or Low (Kit)
-0.5mm	Up ▲	Kit	Low (Kit)
-1.5mm	Down ▼	Kit	Low (Kit)

-1.5mm

DIFF or Spool Height

+2.0mm

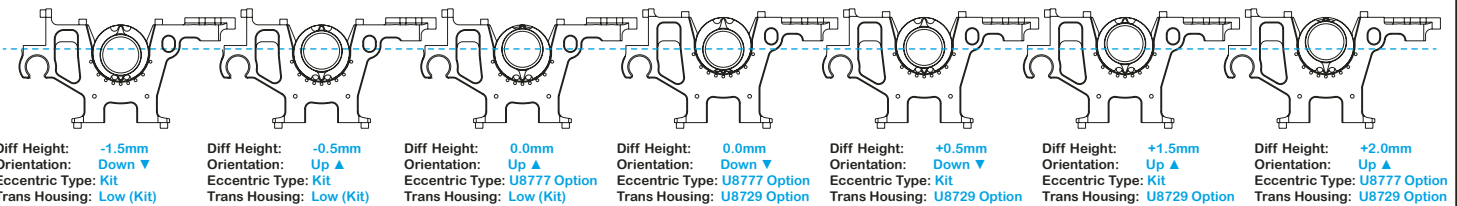

WEIGHT DISTRIBUTION

There are several positions intended for weight placement in the front and rear of the car. Please see the setup sheet for suggested placements. We recommend the use of U8773 and U8774 for this.

Please note that the mass damper (U8137) can be used within each wishbone (x4 places).

For the most neutral car balance, we recommend a 50:50 weight distribution. This is easily achieved with no weights and centrally placed electronics.

More rearwards weight generally gives a more aggressive car with more steering.

More forwards weight generally gives a smoother car handling with less steering.

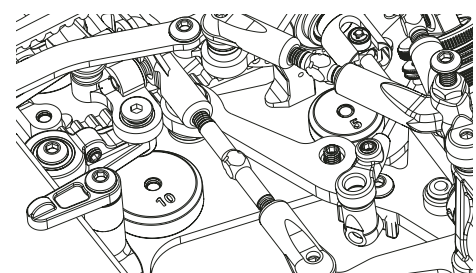

ACKERMANN

See Page 14 Step 14

The front steering arm features two positions for different Ackermann. Position A provides the most Ackermann. This gives a smoother steering feeling and is the best option for an easier to drive car. This is the most common position and preferred by the team for most large outdoor tracks. Position B provides the least Ackermann. This gives a more aggressive steering feeling and is the best option when more steering rotation is required. Best used when maximum mid corner steering is required. This is a good option for very technical outdoor tracks.

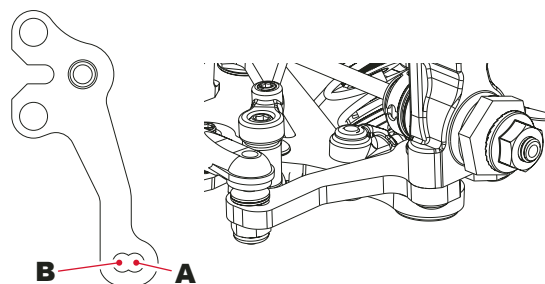
**BODY HEIGHT**

See Pages 25 & 26 Steps 23a & 23c

The height of the body is very important to performance. Height 'A' must be between 110mm and 115mm. Higher here provides more rear grip and improved drivability. We suggest 113mm as a good starting height.

To set height 'B' (see page 12 to locate 'body stop screws')

- 1) Remove spring hangers from the body posts temporarily.
- 2) Adjust the body stop screws to set 'B' to between 2mm-4mm.
- 3) Fit body hangers to the posts to achieve a 'B' height between 5mm-6mm.

This allows to run the body lower to gain front downforce without excessive touching against the track surface.

If you prefer not to use the body stop screws, set 'B' to between 8mm-9mm.

Height 'C' should be cut to achieve a height of between 6mm-9mm. Adjust if excessive touching occurs.

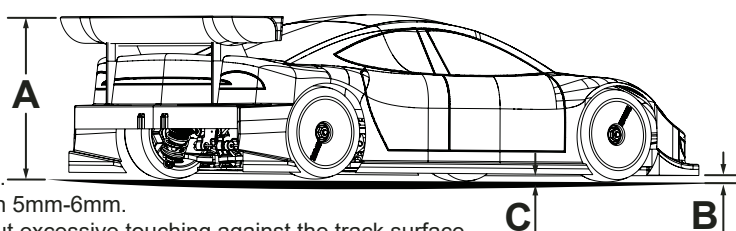
**SHOCK OIL**

See Page 23 Step 20

The aim is to achieve improved handling over bumps and control the weight transfer of the car.

If the track is particularly bumpy, increase the shock oil viscosity to help handling over bumps.

If the traction is low, lowering the shock oil to improve weight transfer and generate more grip.

If the traction is high, increasing the shock oil to make the car smoother and less unpredictable.

In higher temperature, increase the shock oil to manage tyre temperature.

Our suggested range is between 250cSt and 600cSt, when using Core-Rc shock oil with kit pistons.

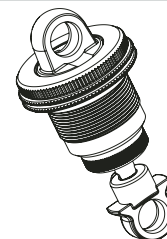
**TOP DECK FLEX OPTIONS**

See Page 8 Step 6c

The C/F chassis kit includes a 1 piece topdeck with 2 stiffness screw options. The rear stiffness screw offers more flexibility. The front stiffness screw makes the chassis stiffer. (C/F Chassis Kit position).

The Aluminium chassis kit includes a split S2, 2 piece 1.6mm topdeck design. The front topdeck has 2 dowels and screws. (Aluminium Chassis kit has only one screw nearest the spur gear).

Adding an additional dowel and screw into the forward position may make the car more responsive, but this option is rarely used by the team.

The rear top deck has 3 dowel/screw positions, the rear offering more stability and the front offers the most steering/rotation.

We also offer a 2.0mm, C/F version of the split topdeck which will make the car safer to drive.

All the top deck options are compatible with both chassis options.

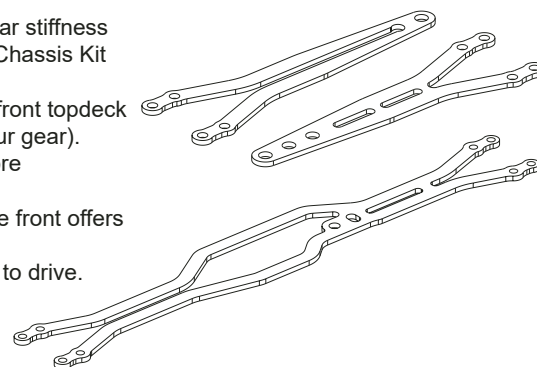
**UPPER INNER LINK LENGTH**

See Page 9 Step 7a

The upper link length can be adjusted using speed secret CF link mounts - U8779, U8780, U8781.

These lengthen the upper link length by 1mm and are best suited to lower grip conditions or for providing more grip to the front or rear. (whichever end of the car they are fitted to.)

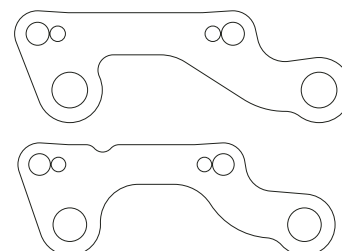

OPTION PARTS



U8772
Alloy Spring Seat - Mi9 (pk4)



U8708
Alloy TC Impact Servo Saver Horn



U8709
Pro TC Impact Servo Saver



U8762
Alloy Narrow Wheel Hex (-0.75mm) - Mi9 (pr)



U8730
Alloy Hub Carrier - Mi9 (pr)



U8775
Dowel Bush (For 1.6mm Top Decks) - Mi9 (pk4)



U8768
Alloy Lower Shock Mount - Mi9 (pk4)



U8771
Alloy Castor Pointer - Mi9 (pr)

OPTION PARTS



U8777
Alloy Eccentric (+0.5mm Offset) - Mi9 (pr)



U8776
Alloy Eccentric - Mi9 (pr)



- U8253** CNC Stock Spur Gear 98T 64DP
- U8254** CNC Stock Spur Gear 104T 64DP
- U8255** CNC Stock Spur Gear 108T 64DP
- U8785** CNC Spur Gear 112T 64DP
- U8786** CNC Spur Gear 113T 64DP
- U8787** CNC Spur Gear 114T 64DP



U8335
Brass Shorty Lipo Set (pr)



U8770
K-Coat Nano Shock Body - Mi9 (pk4)



U8753
Anti-Roll Bar Wire Set - (pk8)
2 x 1.1mm, 2 x 1.2mm, 2 x 1.3mm, 2 x 1.4mm



U7816
Alloy Radius Arms



U7837
C/F Upper Bumper

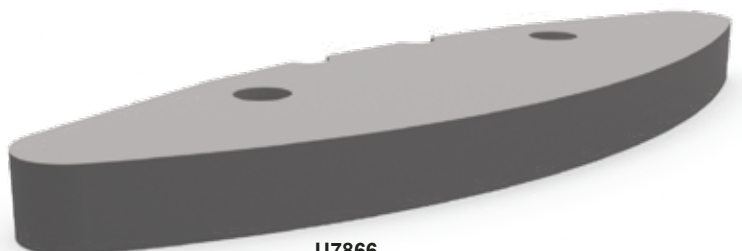

U7866
Lightweight Foam Bumper

SPARES LISTS

Chassis Parts

U119	Aerial Tube - Pack 4
U4741	6mm Offset Servo Arms
U4773	Aerial Mount
U4872	Centre Track Rod Shim pk4 - Mi6/evo,7,8
U4950	Body Posts 4pcs - E1-E5,A2/3,FT,ST/2,Icon/2,FT8
U7738	Radius Arms pr - Mi7,FT,Mi8,FT8
U7750	LiPo Mounting Mouldings set - Mi7,FT,Mi8,FT8
U7769	Alloy Centre Track Rod Assy - Mi7,Mi8
U7773	Alloy Steering Pivots/Spacers - Mi7,Mi8 (pr)
U7783	Dowel Bush pk4 - Mi7,FT,Mi8
U7790	Foam Bumper - Mi7,FT,Mi8
U8261	Alloy Shock Top Ball - Mi8,FT8 (pr)
U8316	Front Bumper Mouldings - Mi8,FT8
U8563	C/F Chassis - Mi8 HGT Conversion
U8568	C/F 1 Piece Top Deck 2mm - Mi8 HGT Conversion
U8571	S2 Split Top Decks 1.6mm - Mi8 HGT Conversion (pr)
U8645	Alloy Chassis - Mi8 HGT Conversion
U8727	Alloy Servo Mount - Mi9
U8728	Alloy Trans Housing Low - Mi9 (pr)
U8729	Alloy Trans Housing High - Mi9 (pr)
U8754	Alloy Motor Mount - Mi9
U8755	C/F Rear Shock Mount - Mi9
U8756	C/F Front Shock Mount - Mi9 (pr)
U8757	C/F Front Link Mount - Mi9 (pr)
U8758	C/F Rear Link Mount RH - Mi9
U8767	C/F Bumper Crash Stop - Mi9
U8778	C/F Rear Link Mount LH - Mi9
U8795	Manual - Mi9

Bodyshells & Decals

MR33-RW05	MR33 Touring Rear Wing 0.5mm v2
MT018002H	Montech Wing Hard 1mm
MT018003M	Montech Wing Medium 0.75mm
MT019013	Montech Montecarlo Body - Std
MT019013L	Montech Montecarlo Body - Light Weight
MT019013SL	Montech Montecarlo Superleggera Body
MT019018	Montech YSOT Body Standard
MT019018L	Montech YSOT Body Light Weight
MT021001	Montech IMOLA TC Body - Standard
MT021001L	Montech IMOLA TC Body - Lightweight
MT0210111	Montech Zero TC Body - Standard
MT0210111L	Montech Zero TC Body - Lightweight
U4806	Touring Car Wheel Arch Cutting Jig
U5119	Touring Car Wing + 2 End Plates - Clear
U5120	Touring Car Wing + 2 End Plates - Black
U5121	Touring Car Wing + 2 End Plates - Carbon
U8586	Schumacher Decal Sheet - Black - pk2
U8587	Schumacher Decal Sheet - Neon Blue - pk2
U8588	Schumacher Decal Sheet - Neon Green - pk2
U8589	Schumacher Decal Sheet - Neon Orange - pk2
U8590	Schumacher Decal Sheet - Neon Pink - pk2
U8796	Decal - Mi9
XTMTB0413-ETS	Xtreme Twister - ETS TC Body
XTMTB0413-L	Xtreme Twister - Light TC Body
XTMTB0413-UL	Xtreme Twister - Ultra Light TC Body
XTMTB0415-UL	Xtreme Twister Speciale - Ultra Light TC Body
XTMTB0418-ETS	Xtreme Brutale - ETS Body
XTMTB0418-L	Xtreme Brutale - Light TC Body
XTMTB0418-UL	Xtreme Brutale - Ultra Light TC Body

Suspension

U4900	Roll Bar Clamp pr - Mi6/evo,Mi8,FT8
U4903	Precision Ball Stud Ultra Short - pk4
U4904	Precision Ball Stud Short - pk4
U7747	Wishbone ARB Mount - Mi7,Mi8,FT8 (pr)
U7832	Ball Stud Low (Ultra Short) (pk4)
U7834	Ball Stud Low (Long) (pk4)
U8168	5 x 1 'O' ring (pk10)
U8219	Alloy ARB Drop Link - Mi8,FT8 (pr)
U8235	Optional Alloy Upper Link Pivot Rear-Mi8,FT8 (pr)

U8252	Optional Alloy Upper Link Pivot Front-Mi8,FT8 (pr)
U8259	Roll Bar Socket - Mi8,FT8 (pk4)
U8263	Alloy M3 Turnbuckle - 25mm - Black (pr)
U8264	Alloy M3 Turnbuckle - 35mm - Black (pr)
U8265	Alloy M3 Turnbuckle - 45mm - Black (pr)
U8719	Lower Shock Ball - Mi9 (pk4)
U8743	Hub Carrier - Mi9 (pr)
U8744	Alloy Wishbone Spacer 0.5mm - Mi9 (pk8)
U8745	Alloy Wishbone Spacer 1mm - Mi9 (pk8)
U8746	Alloy Wishbone Spacer 2mm - Mi9 (pk8)
U8747	Inner Wishbone Ball - Mi9 (pk4)
U8751	Lower Shock Mount - Mi9 (pk4)
U8752	Outer Wishbone Ball Stud - Mi9 (pk4)
U8760	C/F Front Wishbone - Mi9
U8761	C/F Rear Wishbone - Mi9
U8763	C/F Steering Arm RR - Mi9
U8764	C/F Steering Arm RL - Mi9
U8765	C/F Steering Arm FR - Mi9
U8766	C/F Steering Arm FL - Mi9
U8769	Wishbone Outer Socket - Mi9 (pk4)
U8783	Black Upper Link Sockets - Mi9 (pk8)
U8784	Black 5.5mm Pivot Ball Socket - Mi9 (pk8)

Shock Absorbers

U4557	Shock Seal Cap 1pr - Mi5evo,Mi7,FT8
U7463	Ultra Short Shock Seal 'O' Ring pk4 - Mi6-8,FT8
U7537	Ultra Short Shock Piston 4H pr - Mi6-8,FT8
U7545	Ultra Short Shock Shims (3.3x6.7x0.05)-Mi6-7,FT8
U8710	Nano Shock Diaphragm - Mi9 (pk8)
U8711	Nano Shock Top Ring - Mi9 (pr)
U8712	Nano Shock Top Socket - Mi9 (pr)
U8713	Nano Shock Shaft - Mi9 (pr)
U8714	Nano Shock Body - Mi9 (pr)
U8715	Nano Shock Collar O-ring - Mi9 (pk4)
U8716	Nano Alloy Shock Collar - Mi9 (pr)
U8717	Nano Shock Spring Seat - Mi9 (pr)
U8718	Nano Lower Shock Socket - Mi9 (pk4)
U8788	Nano Shock Set - Mi9 (pk4)
U8797	Nano Shock Rebuild Kit - Mi9

Springs

CR840	CORE RC Hi Response TC Spring 1.9 - White
CR841	CORE RC Hi Response TC Spring 2.1 - Red
CR842	CORE RC Hi Response TC Spring 2.3 - Green
CR843	CORE RC Hi Response TC Spring 2.5 - Blue
CR844	CORE RC Hi Response TC Spring 2.6 - Black
CR845	CORE RC Hi Response TC Spring 2.7 - Orange
CR846	CORE RC Hi Response TC Spring 2.8 - Yellow
CR847	CORE RC Hi Response TC Spring 2.9 - Purple
CR848	CORE RC Hi Response TC Spring 2.2-2.9 Brown
CR849	CORE RC Hi Response TC Spring 3.1 - Grey
CR850	CORE RC Hi Response TC Spring 3.3 - Pink
CR851	CORE RC Hi Response TC Spring 3.5 - Grn/Yellow
CR852	CORE RC Hi Response TC Spring Set - Soft
CR853	CORE RC Hi Response TC Spring Set - Med
CR854	CORE RC Hi Response TC Spring Set - Hard
U7539	Ultra Short Shock Springs 3.0 pr - Mi6-8,FT8

Bearings & Balls

H1031	Bearing Blaster Aerosol 500ml
U1411	Ball Bearing - 4x8x3 Shield - (pr)
U1957	Moly Grease - Pot 5ml
U3136	Ball Bearing - 5x8x2.5 - Shield (pr)
U4943	Ball Bearing - 1/8 x 1/4 Shield - (pr)
U4945	Pro Ball Bearing 1/8 x 1/4 x 7/64 - pr
U7794	Ball Bearing 3/16"x5/16" Flanged Yellow (pr)
U7822	Pro Ball Bearing 3/16"x5/16"x1/8" Flanged (pr)
U8320	Ball Bearing 3/16"x5/16" Yellow (pr)
U8790	Ball Bearing 6x10x3 Yellow Shield - pr
U8791	Ball Bearing Set - Mi9

SPARES LISTS

Transmission

AM348085 Spur Gear 48P - 85T
 U7731 Layshaft Fences - Mi7,Mi8,FT8
 U7735 Diff Gears and Pin - Mi7,Mi8,FT8
 U7779 Layshaft - Mi7,Mi8,FT8
 U7781 Spur Gear Screw - Mi7,Mi8,FT8 (pk3)
 U8232 Alloy Layshaft Pulley - Mi8
 U8262 Belt 119T - Mi8
 U8720 Alloy Wheel Hex - Mi9 (pr)
 U8721 Alloy Spool Hub - Mi9
 U8722 Spool Pulley & Fence - Mi9
 U8723 Gear Diff Rebuild Kit - Mi9
 U8724 Gear Diff Mouldings - Mi9
 U8725 Eccentrics - Mi9 (pr)
 U8726 Diff Output Shaft - Mi9 (pr)
 U8731 Front Axle - Mi9
 U8732 Front Driveshaft Bone - Mi9
 U8733 Driveshaft Yoke Outer - Mi9
 U8734 Front Driveshaft Cage - Mi9
 U8735 Driveshaft Spring Clip - Mi9 (pr)
 U8736 Driveshaft Pin Outer - Mi9 (pr)
 U8737 Driveshaft Yoke Inner - Mi9
 U8738 Front Double Joint Driveshaft - Mi9 (pr)
 U8739 Rear Driveshaft - Mi9 (pr)
 U8740 Wheel Bearing Spacer - Mi9 (pr)
 U8741 Rear Axle - Mi9
 U8742 Rear Driveshaft Bone - Mi9
 U8748 Diff/Spool End Float Shim 6x7.7x0.1mm - Mi9 (pk4)
 U8749 Diff Output - Mi9 (pr)
 U8750 Spool Output - Mi9 (pr)
 U8789 Gear Diff Set - Mi9
 U8792 3.5 x 1 'O'ring (pk10) - Mi9
 U8793 E Clip 1.2 ID x 3 OD x 0.3 - Mi9 (pk10)
 U8798 Ball Bearing 1.5x4x2 Shield - pr
 U8799 Pro Ball Bearing 6x10x3 - pr
 U8800 Pro Ball Bearing Set - Mi9

Pinions

CR4818 Pinion Gear 48DP 18T (7075 Hard)
 CR4819 Pinion Gear 48DP 19T (7075 Hard)
 CR4820 Pinion Gear 48DP 20T (7075 Hard)
 CR4821 Pinion Gear 48DP 21T (7075 Hard)
 CR4822 Pinion Gear 48DP 22T (7075 Hard)
 CR4823 Pinion Gear 48DP 23T (7075 Hard)
 CR4824 Pinion Gear 48DP 24T (7075 Hard)
 CR4825 Pinion Gear 48DP 25T (7075 Hard)
 CR4826 Pinion Gear 48DP 26T (7075 Hard)
 CR4827 Pinion Gear 48DP 27T (7075 Hard)
 CR4828 Pinion Gear 48DP 28T (7075 Hard)
 CR4829 Pinion Gear 48DP 29T (7075 Hard)
 CR4830 Pinion Gear 48DP 30T (7075 Hard)
 CR4831 Pinion Gear 48DP 31T (7075 Hard)
 CR4832 Pinion Gear 48DP 32T (7075 Hard)
 CR4833 Pinion Gear 48DP 33T (7075 Hard)
 CR4834 Pinion Gear 48DP 34T (7075 Hard)
 CR4835 Pinion Gear 48DP 35T (7075 Hard)
 CR4836 Pinion Gear 48DP 36T (7075 Hard)
 CR4837 Pinion Gear 48DP 37T (7075 Hard)
 CR4838 Pinion Gear 48DP 38T (7075 Hard)
 CR4839 Pinion Gear 48DP 39T (7075 Hard)
 CR4840 Pinion Gear 48DP 40T (7075 Hard)
 CR4841 Pinion Gear 48DP 41T (7075 Hard)
 CR4842 Pinion Gear 48DP 42T (7075 Hard)
 CR4843 Pinion Gear 48DP 43T (7075 Hard)
 CR4844 Pinion Gear 48DP 44T (7075 Hard)
 CR4845 Pinion Gear 48DP 45T (7075 Hard)
 CR4846 Pinion Gear 48DP 46T (7075 Hard)
 CR6424 Pinion Gear 64DP 24T (7075 Hard)
 CR6425 Pinion Gear 64DP 25T (7075 Hard)
 CR6426 Pinion Gear 64DP 26T (7075 Hard)
 CR6427 Pinion Gear 64DP 27T (7075 Hard)
 CR6428 Pinion Gear 64DP 28T (7075 Hard)

CR6429 Pinion Gear 64DP 29T (7075 Hard)
 CR6430 Pinion Gear 64DP 30T (7075 Hard)
 CR6431 Pinion Gear 64DP 31T (7075 Hard)
 CR6432 Pinion Gear 64DP 32T (7075 Hard)
 CR6433 Pinion Gear 64DP 33T (7075 Hard)
 CR6434 Pinion Gear 64DP 34T (7075 Hard)
 CR6435 Pinion Gear 64DP 35T (7075 Hard)
 CR6436 Pinion Gear 64DP 36T (7075 Hard)
 CR6437 Pinion Gear 64DP 37T (7075 Hard)
 CR6438 Pinion Gear 64DP 38T (7075 Hard)
 CR6439 Pinion Gear 64DP 39T (7075 Hard)
 CR6440 Pinion Gear 64DP 40T (7075 Hard)
 CR6441 Pinion Gear 64DP 41T (7075 Hard)
 CR6442 Pinion Gear 64DP 42T (7075 Hard)
 CR6443 Pinion Gear 64DP 43T (7075 Hard)
 CR6444 Pinion Gear 64DP 44T (7075 Hard)
 CR6445 Pinion Gear 64DP 45T (7075 Hard)
 CR6446 Pinion Gear 64DP 46T (7075 Hard)
 CR6447 Pinion Gear 64DP 47T (7075 Hard)
 CR6448 Pinion Gear 64DP 48T (7075 Hard)
 CR6449 Pinion Gear 64DP 49T (7075 Hard)
 CR6450 Pinion Gear 64DP 50T (7075 Hard)
 CR6451 Pinion Gear 64DP 51T (7075 Hard)
 CR6452 Pinion Gear 64DP 52T (7075 Hard)
 CR6453 Pinion Gear 64DP 53T (7075 Hard)
 CR6454 Pinion Gear 64DP 54T (7075 Hard)
 CR6455 Pinion Gear 64DP 55T (7075 Hard)
 CR6456 Pinion Gear 64DP 56T (7075 Hard)
 CR6457 Pinion Gear 64DP 57T (7075 Hard)
 CR6458 Pinion Gear 64DP 58T (7075 Hard)
 CR6459 Pinion Gear 64DP 59T (7075 Hard)
 CR6460 Pinion Gear 64DP 60T (7075 Hard)
 CR6461 Pinion Gear 64DP 61T (7075 Hard)
 CR6462 Pinion Gear 64DP 62T (7075 Hard)
 U3418 Pinion; Hard Alloy 48dp - 18T
 U3419 Pinion; Hard Alloy 48dp - 19T
 U3420 Pinion; Hard Alloy 48dp - 20T
 U3421 Pinion; Hard Alloy 48dp - 21T
 U3422 Pinion; Hard Alloy 48dp - 22T
 U3423 Pinion; Hard Alloy 48dp - 23T
 U3424 Pinion; Hard Alloy 48dp - 24T
 U3425 Pinion; Hard Alloy 48dp - 25T
 U3426 Pinion; Hard Alloy 48dp - 26T
 U3427 Pinion; Hard Alloy 48dp - 27T
 U3428 Pinion; Hard Alloy 48dp - 28T
 U3429 Pinion; Hard Alloy 48dp - 29T
 U3430 Pinion; Hard Alloy 48dp - 30T
 U3431 Pinion; Hard Alloy 48dp - 31T
 U3432 Pinion; Hard Alloy 48dp - 32T
 U3433 Pinion; Hard Alloy 48dp - 33T
 U3434 Pinion; Hard Alloy 48dp - 34T
 U3435 Pinion; Hard Alloy 48dp - 35T
 U3436 Pinion; Hard Alloy 48dp - 36T
 U3437 Pinion; Hard Alloy 48dp - 37T
 U3438 Pinion; Hard Alloy 48dp - 38T
 U3439 Pinion; Hard alloy 48dp - 39T
 U3440 Pinion; Hard Alloy 48dp - 40T
 U3619 Pinion; Hard Alloy 64dp - 19T
 U3620 Pinion; Hard Alloy 64dp - 20T
 U3621 Pinion; Hard Alloy 64dp - 21T
 U3622 Pinion; Hard Alloy 64dp - 22T
 U3623 Pinion; Hard Alloy 64dp - 23T
 U3624 Pinion; Hard Alloy 64dp - 24T
 U3625 Pinion; Hard Alloy 64dp - 25T
 U3626 Pinion; Hard Alloy 64dp - 26T
 U3627 Pinion; Hard Alloy 64dp - 27T
 U3628 Pinion; Hard Alloy 64dp - 28T
 U3629 Pinion; Hard Alloy 64dp - 29T
 U3630 Pinion; Hard Alloy 64dp - 30T
 U3631 Pinion; Hard Alloy 64dp - 31T
 U3632 Pinion; Hard Alloy 64dp - 32T
 U3633 Pinion; Hard Alloy 64dp - 33T
 U3634 Pinion; Hard Alloy 64dp - 34T

SPARES LISTS

U3635	Pinion; Hard Alloy 64dp - 35T
U3636	Pinion; Hard Alloy 64dp - 36T
U3637	Pinion; Hard Alloy 64dp - 37T
U3638	Pinion; Hard Alloy 64dp - 38T
U3639	Pinion; Hard Alloy 64dp - 39T
U3640	Pinion; Hard Alloy 64dp - 40T
U3641	Pinion; Hard Alloy 64dp - 41T
U3642	Pinion; Hard Alloy 64dp - 42T
U3643	Pinion; Hard Alloy 64dp - 43T
U3644	Pinion; Hard Alloy 64dp - 44T
U3645	Pinion; Hard Alloy 64dp - 45T
U3646	Pinion; Hard Alloy 64dp - 46T
U3647	Pinion; Hard Alloy 64dp - 47T
U3648	Pinion; Hard Alloy 64dp - 48T
U3649	Pinion; Hard Alloy 64dp - 49T
U3650	Pinion; Hard Alloy 64dp - 50T

Hardware

CR024	CORE RC - Serrated M4 Steel Wheel Nut pk4
CR035	CORE RC - Serrated Alloy M4 Nuts; Blue pk 4
CR036	CORE RC - Serrated Alloy M4 Nuts; Violet pk 4
CR060	Small Body Clip 1/10 - Gloss Black (8)
CR061	Small Body Clip 1/10 - Silver (8)
CR062	Small Body Clip 1/10 - Gold (8)
CR063	Small Body Clip 1/10 - Fluorescent Yellow (8)
CR064	Small Body Clip 1/10 - Fluorescent Green (8)
CR065	Small Body Clip 1/10 - Fluorescent Red (8)
CR066	Small Body Clip 1/10 - Metallic Green (8)
CR067	Small Body Clip 1/10 - Metallic Red (8)
CR068	Small Body Clip 1/10 - Metallic Blue (8)
CR069	Small Body Clip 1/10 - Metallic Purple (8)
CR071	Big Body Clip 1/10 - Silver (8)
CR072	Big Body Clip 1/10 - Gold (8)
CR074	Big Body Clip 1/10 - Fluorescent Green (8)
CR076	Big Body Clip 1/10 - Metallic Green (8)
CR077	Big Body Clip 1/10 - Metallic Red (8)
CR078	Big Body Clip 1/10 - Metallic Blue (8)
CR079	Big Body Clip 1/10 - Metallic Purple (8)
CR081	Extra Long Body Clip 1/10 - Silver (6)
CR082	Extra Long Body Clip 1/10 - Gold (6)
CR083	Extra Long Body Clip 1/10 - Fluorescent Yellow (6)
CR084	Extra Long Body Clip 1/10 - Fluorescent Green (6)
CR085	Extra Long Body Clip 1/10 - Fluorescent Red (6)
CR086	Extra Long Body Clip 1/10 - Metallic Green (6)
CR087	Extra Long Body Clip 1/10 - Metallic Red (6)
CR088	Extra Long Body Clip 1/10 - Metallic Blue (6)
CR089	Extra Long Body Clip 1/10 - Metallic Purple (6)
CR196	CORE RC - Serrated Alloy M4 Nuts - Black - pk4
CR638	Rubber Body Clip Pulls - pk12
CR879	CORE RC - Serrated M4 Steel Black Wheel Nut pk4
U1550	SPEED PK-Socket Wrenches-1.5/2.0/2.5/3.0mm
U1633	SPEED PACK - Small Pins (pk)
U2128	SPEED PACK - Grub-Set Screws M3 M4
U3021	SPEED PACK - M3x6 Csk Hd - (pk10)
U3022	SPEED PACK - M3x8 Csk Hd - (pk10)
U3023	SPEED PACK - M3x10 Csk Hd - (pk10)
U3131	Alloy Spacers - M3x7mm 0.5;1;2mm (pk18)
U4155	SPEED PACK - M3 Csk Washers - Black Alloy (pk10)
U4210	SPEED PACK - Pinion Grub Screw Set pk10
U4241	SPEED PACK - M3 Alloy Nyloc Nuts - Black - pk10
U4254	Ball Grippa Sockets Pro pk8
U4314	SPEED PACK - Alloy Black M3 Washers - 18pc
U4835	SPEED PACK - M3 Steel Nut Black (pk8)
U4836	SPEED PACK Grub Screw M3 x 8mm Cup Point (10pcs)
U4862	Black Alloy Washers 0.50mm (pk12)
U4987	SPEED PACK Needle Roller 1.5x11.8 (pk8)
U7102	SPEED PACK - M3x4 Button Hd (pk10)
U7103	SPEED PACK - M3x6 Button Hd (pk10)
U7104	SPEED PACK - M3x8 Button Hd (pk10)
U7105	SPEED PACK - M3x10 Button Hd (pk10)
U7106	SPEED PACK - M3x12 Button Hd (pk10)

U7107	SPEED PACK - M3x16 Button Hd (pk10)
U7122	SPEED PACK - M3x12 Csk Hd (pk10)
U7538	SPEED PACK M2x6 CSK pk 10
U7677	SPEED PACK - M2.5x8 Csk Hd (pk10)
U7709	M3 Black Alloy Washers 0.75mm (pk10)
U7710	M3 Black Alloy Washers 1.00mm (pk10)
U7711	M3 Black Alloy Washers 2.00mm (pk10)
U7712	M3 Black Alloy Washers 3.00mm (pk10)
U7751	M3x8 Grub Screw Dome End (pk4)
U7774	M3 Alloy Washer Black 1.5 mm (pk10)
U8336	Pro Body Clips (pk 10)
U8536	M3x4 Grub Screw Cup Point - (pk10)
U8759	Steel Spanner 3.9/5.5mm - Mi9
U8794	M3 Brass Black Thread Inserts - pk10
U8801	SPEED PACK - M3x5 Button Hd (pk10)

Options

AX030	Aerox On-Road Alloy Servo Arm - Offset 23T Sanwa
AX031	Aerox On-Road Alloy Servo Arm - Offset 25T Futaba
AX067	Aerox LP1s Servo
AM030106	Alloy Servo Horn 23T BG
AM030107	Alloy Servo Horn 25T BG
AM348069	Spur Gear 48P - 69T
AM348070	Spur Gear 48P - 70T
AM348071	Spur Gear 48P - 71T
AM348072	Spur Gear 48P - 72T
AM348073	Spur Gear 48P - 73T
AM348074	Spur Gear 48P - 74T
AM348075	Spur Gear 48P - 75T
AM348078	Spur Gear 48P - 78T
AM348081	Spur Gear 48P - 81T
AM348082	Spur Gear 48P - 82T
AM348083	Spur Gear 48P - 83T
AM348084	Spur Gear 48P - 84T
AM348086	Spur Gear 48P - 86T
AM348087	Spur Gear 48P - 87T
AM364090	Spur Gear 64P - 90T
AM364092	Spur Gear 64P - 92T
AM364094	Spur Gear 64P - 94T
AM364096	Spur Gear 64P - 96T
AM364098	Spur Gear 64P - 98T
AM364100	Spur Gear 64P - 100T
AM364102	Spur Gear 64P - 102T
AM364104	Spur Gear 64P - 104T
AM364106	Spur Gear 64P - 106T
AM364108	Spur Gear 64P - 108T
AM364110	Spur Gear 64P - 110T
AM364112	Spur Gear 64P - 112T
AM364114	Spur Gear 64P - 114T
AM364116	Spur Gear 64P - 116T
CR280	Ti Pro Ball Studs - Short - (pr)
CR304	Titanium Wheel Nuts M4 - pk4
CR310	Alloy Csk Hex Screws M3 x 6 pk10
CR311	Alloy Csk Hex Screws M3 x 8 pk10
CR312	Alloy Csk Hex Screws M3 x 10 pk10
CR313	Alloy Csk Hex Screws M3 x 12 pk10
CR314	Alloy Button Head Hex Screws M3 x 6 pk10
CR315	Alloy Button Head Hex Screws M3 x 8 pk10
CR316	Alloy Button Head Hex Screws M3 x 10 pk10
CR317	Alloy Button Head Hex Screws M3 x 12 pk10
CR465	Alloy Offset Servo Arm 23T - Sanwa/KO
CR466	Alloy Offset Servo Arm 25T - Futaba
CR664	Alloy Motor Spacer - 1mm - pk2
CR723	Threaded Steel 10g Weight 17.60mm (pk4)
CR868	Threaded Square 5g Weight - (pk4)
CR869	Threaded Rectangular 7.5g Weight - (pk4)
MR33-AAS23T	MR33 Adjustable Servo Horn 23t Sanwa
MR33-AAS25T	MR33 Adjustable Servo Horn 25t Futaba
U3582	Precision Balance Pivot Set
U4235	M3 x 8mm Alloy Csk Screws pk10
U4236	M3 x 10mm Alloy Csk Screws pk10
U4328	Impact Servo Saver 23T/25T

SPARES LISTS

- U4329 Impact Servo Saver Mouldings - Mi5-Mi7,FT,E4,Icon
- U4330 Impact Servo Saver Springs - Mi5-Mi7,FT,E4,Icon
- U7400 Titanium Low Profile M4 Serrated Nut (pk4)
- U7536 Ultra Short Shock Piston 3H pr - Mi6/evo,7,8
- U7689 M3 Brass Inserts - pk10
- U7816 Alloy Radius Arms - Mi7,Mi8 (pr)
- U7820 Spur Gear 120T 64dp CNC - Mi7,Mi8,FT8
- U7821 Spur Gear 89T 48dp CNC - Mi7,Mi8,FT8
- U7827 Alloy LiPo Mount pr - Mi7,FT,Mi8,FT8
- U7828 Titanium Ball Stud Low (Ultra Short) (pk4)
- U7837 C/F Upper Bumper - Mi7,FT,Mi8,FT8
- U7839 C/F LiPo Swivel pr - Mi7,FT,Mi8,FT8,LD3,ST2
- U7866 Lightweight Foam Bumper - Mi7,FT,Mi8
- U8065 M3 Alloy Thread Insrt pk8-L1,Mi7/8,E3-E5,A2/3,lc/2
- U8185 Upper Wishbone Conversion - Mi8
- U8253 CNC Stock Spur Gear 98T 64DP - Mi8,FT8
- U8254 CNC Stock Spur Gear 104T 64DP - Mi8,FT8
- U8255 CNC Stock Spur Gear 108T 64DP - Mi8,FT8
- U8256 Alloy T Brace - Mi8,FT8
- U8310 High Power Belt Roller - Mi8
- U8318 CNC Stock Spur Gear 92T 64DP - Mi8,FT8
- U8323 C/F Lipo Hook - Mi8,FT8 (pr)
- U8333 Wheel Hex Spacers 0.25, 0.5, 0.75mm - (pk12)
- U8334 Alloy LiPo Swivel - Mi8,L1R,FT8,ST2,LD3 (pr)
- U8335 Brass Shorty Lipo Set - Mi8 - (pr)
- U8570 C/F Split Top Decks 2mm - Mi8 HGT Conversion (pr)
- U8572 Pro Layshaft Bearings - 3/16 x 5/16 x 1/8 pr - Mi8
- U8708 Alloy TC Impact Servo Saver Horn
- U8709 Pro TC Impact Servo Saver
- U8730 Alloy Hub Carrier - Mi9 (pr)
- U8753 Anti-Roll Bar Wire Set - Mi9 (pk8)
- U8762 Alloy Narrow Hex (-0.75mm) - Mi9 (pr)
- U8768 Alloy Lower Shock Mount - Mi9 (pk4)
- U8770 K-Coat Nano Shock Body - Mi9 (pk4)
- U8771 Alloy Castor Pointer - Mi9 (pr)
- U8772 Alloy Spring Seat - Mi9 (pk4)
- U8773 Brass Circular Weight 5g (pk4)
- U8774 Brass Circular Weight 10g (pk4)
- U8775 Dowel Bush (For 1.6mm Top Decks) - Mi9 (pk4)
- U8776 Alloy Eccentric - Mi9 (pr)
- U8777 Alloy Eccentric (+0.5mm Offset) - Mi9 (pr)
- U8779 C/F 1 Notch Rear Link Mount RH - Mi9
- U8780 C/F 1 Notch Rear Link Mount LH - Mi9
- U8781 C/F 1 Notch Front Link Mount - Mi9 (pr)
- U8782 Ti Lower Shock Ball 5mm (2mm Hex) - Mi9 (pk4)
- U8785 CNC Spur Gear 112T 64dp - Mi9
- U8786 CNC Spur Gear 113T 64dp - Mi9
- U8787 CNC Spur Gear 114T 64dp - Mi9

NOTES

Wheels

- U2500 Rev-Lite; 24mm - White (Pk4)
- U2777 Rev-Lite; Flex 24mm - White (Pk4)
- U3792 Rev-Lite wheel Std; 20mm - White (Pk4)

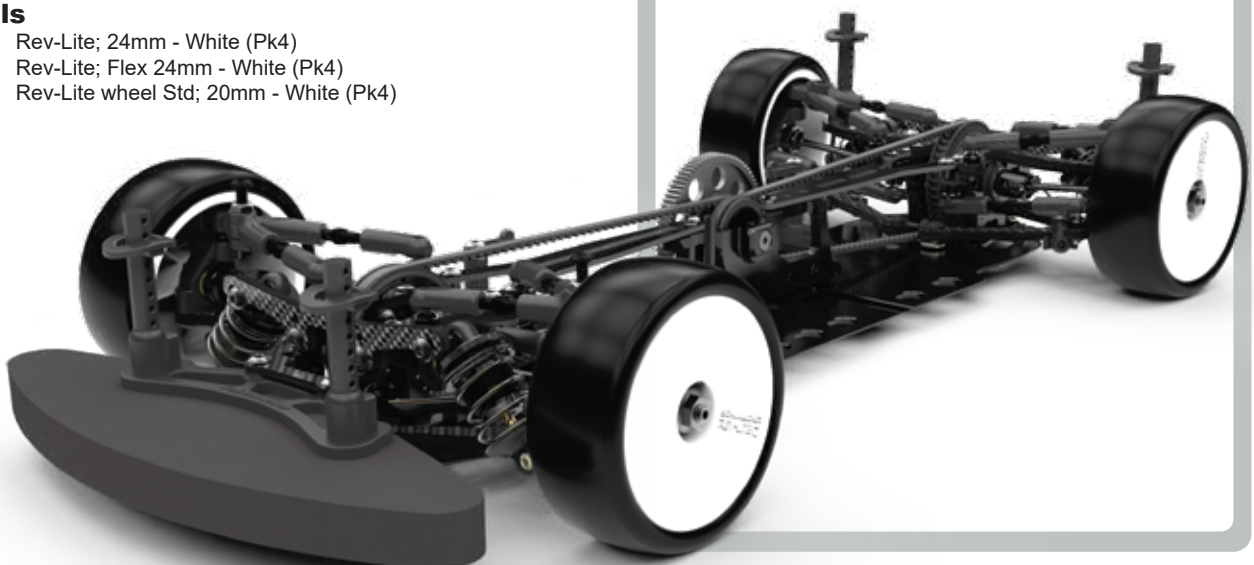

Driver: **Test Driver** Track: **Any Carpet** Event: **Kit build/Easy Setup Alloy Chassis**
 Date: **March 2024** Qualifying: Final: Best Lap:

TRACK TYPE

Grip Level High Medium Low
 Type Tight Open Mixed
 Condition Flat Bumpy Mixed
 Surface Tarmac (Asphalt) Carpet
 Track Temp _____ °C
 Weather _____

Notes:

TYRES

Side Wall Glue Height Ø _____ mm
 Tyres _____
 Cleaner _____
 Additive _____ Wet on track
 Additive Time Front: _____ mins Rear: _____ mins
 Heating Time Front: _____ mins Rear: _____ mins
 Heating Temp Front: _____ °C Rear: _____ °C

Notes:

Kit Build Settings for the Alloy Chassis car on carpet tracks.
 This setup is intended to be easy to drive with smooth, predictable handling.

FRONT

KEY: CF = Carbon Fibre, AL = Aluminium, P = Plastic
 F = Front, R = Rear

Ride Height **5.2** mm
 Camber **2.0** deg
 Droop **23.8** mm
 Castor **4.0** deg
 Toe **1.0/side** deg
 Anti Roll Bar 1.1 1.2 1.3 1.4
 Upper Link Mount 0 Notch 1 Notch
 Spool Height U8777 +0.5mm Alloy Eccentric U8729 High Trans Housing
 Servo Horn Height **18** mm Saver
 Steering Travel **24.0** in _____ out

Notes:

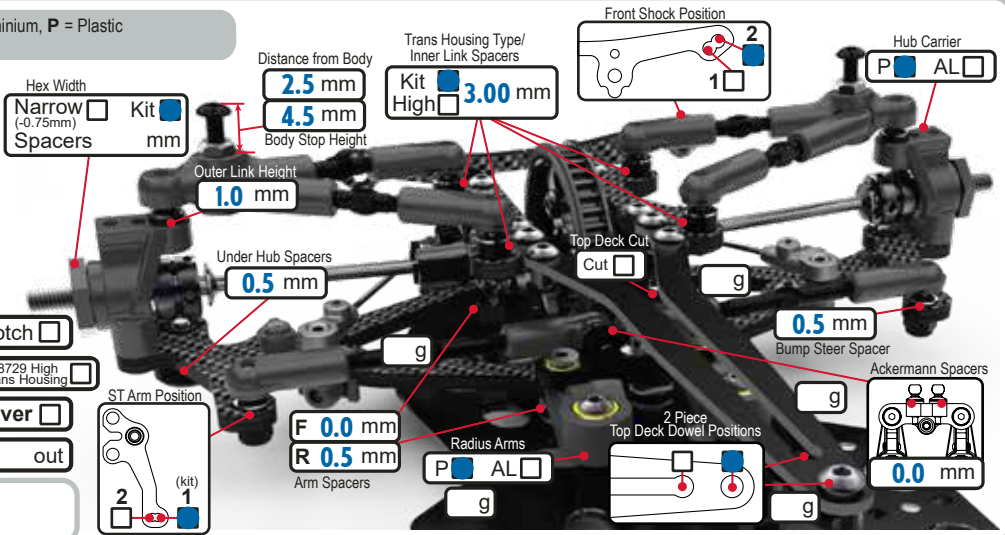

REAR

KEY: CF = Carbon Fibre, AL = Aluminium, P = Plastic
 F = Front, R = Rear

Ride Height **5.4** mm
 Camber **2.0** deg
 Droop **22.6** mm
 Castor **3.0** deg
 Toe **3.5** deg
 Anti Roll Bar 1.1 1.2 1.3 1.4
 Upper Link Mount 0 Notch 1 Notch
 Diff Height U8777 +0.5mm Alloy Eccentric U8729 High Trans Housing
 Diff Setting Diff Checker # _____ **5k** cSt Warming

Notes:

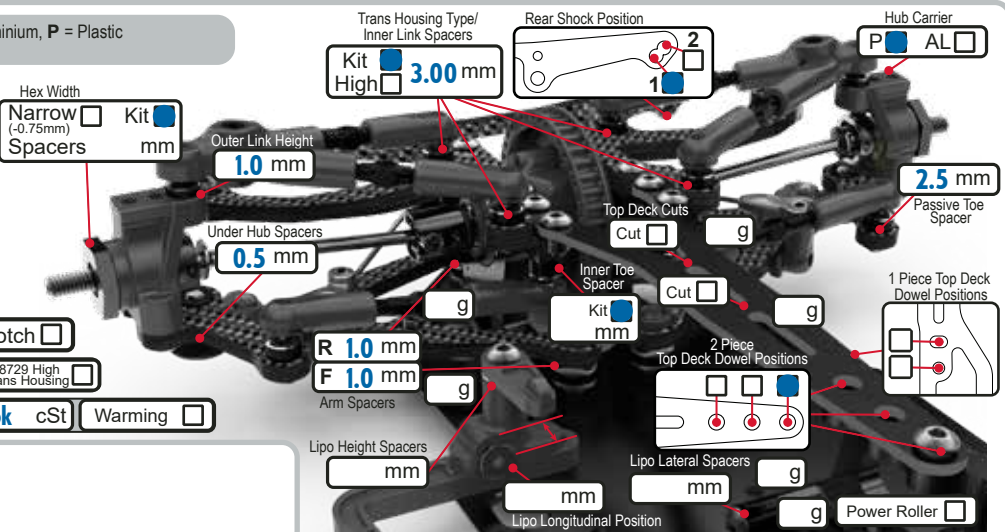

BODYSHELL

Body **Xtreme Speciale**
 Wing **Xtreme Twister**
 Wing Height _____ mm
 Splitter Height _____ mm
 Body Weight _____ g
 Body Offset Fwrd _____ mm
 Wing Offset Rwrdr _____ mm
 Wing End Plates
 Front Post 1dot 2dot 3dot Pin Hole **5**
 Rear Post 1dot 2dot 3dot Pin Hole **10**
 Notes:

CHASSIS

Chassis AL CF
 Top Deck Options CF 1 Piece 2mm
 Front 2 Piece S2 1.6 C/F 1.6 C/F 2.0
 Rear 2 Piece S2 1.6 C/F 1.6 C/F 2.0
 T Brace PTFE Tape
 Motor Mount Screws R F
 Total Weight _____ g
 Weight Distribution Front: _____ : _____ : _____ Rear

ELECTRONICS

E.S.C. _____ + g
 Servo _____
 RX _____ + g
 LiPo _____ + g
 Motor _____ Spacers mm
 Rotor Dia. _____ mm
 Timing _____ deg
 Gear Pitch 48 64
 Pinion _____ t
 Spur _____ t
 Ratio _____

SHOCKS

KEY: x = Stroke, e = external

	FRONT	REAR
Spring	Core-Rc Orange	Core-RC Black
Oil	400 cSt	400 cSt
Piston	Kit <input checked="" type="checkbox"/>	Kit <input type="checkbox"/>
Length (x)	8 mm	8 mm
Rebound	0 mm	0 mm
Limiters (e)	_____ mm	_____ mm
Body	Kit <input checked="" type="checkbox"/>	Kashima Coated <input type="checkbox"/>

Notes:

Driver: **Test Driver** Track: **Any Tarmac** Event: **Kit build/Easy Setup C/F Chassis**
 Date: **March 2024** Qualifying: Final: Best Lap:

TRACK TYPE

Grip Level High Medium Low
 Type Tight Open Mixed
 Condition Flat Bumpy Mixed
 Surface Tarmac (Asphalt) Carpet
 Track Temp _____ °C
 Weather _____

Notes:

TYRES

Side Wall Glue Height Ø _____ mm
 Tyres _____
 Cleaner _____
 Additive _____ Wet on track
 Additive Time Front: _____ mins Rear: _____ mins
 Heating Time Front: _____ mins Rear: _____ mins
 Heating Temp Front: _____ °C Rear: _____ °C

Notes:

Kit Build Settings for the C/F Chassis car on Tarmac/Asphalt tracks.
 This setup is intended to be easy to drive with smooth, predictable handling.

FRONT

KEY: CF = Carbon Fibre, AL = Aluminium, P = Plastic
 F = Front, R = Rear

Ride Height **5.4** mm
 Camber **2.0** deg
 Droop **23.2** mm
 Castor **4.0** deg
 Toe **1.0/side** deg
 Anti Roll Bar 1.1 1.2 1.3 1.4
 Upper Link Mount 0 Notch 1 Notch
 Spool Height U8777 +0.5mm Alloy Eccentric U8729 High Trans Housing
 Servo Horn Height **18** mm Saver
 Steering Travel **24.0** in _____ out

Notes:

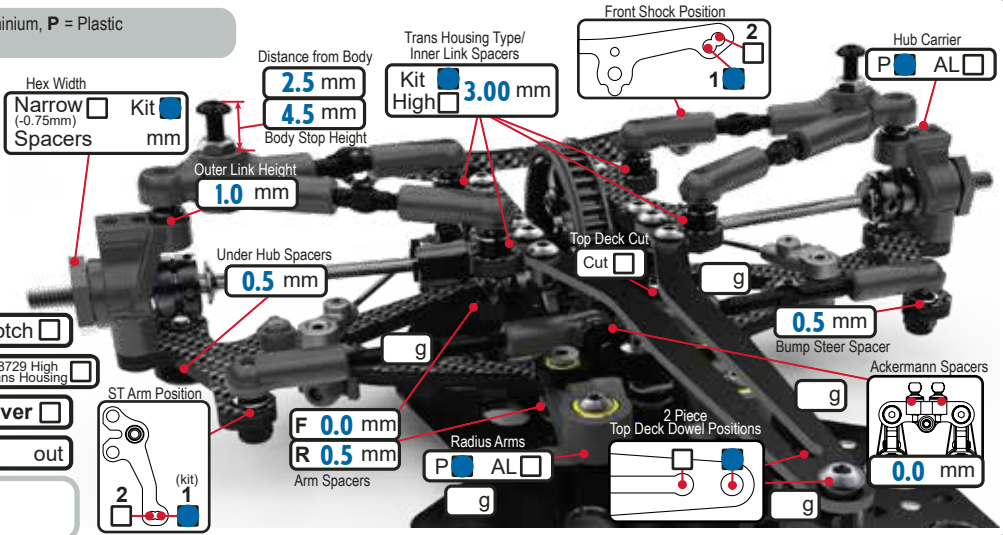

REAR

KEY: CF = Carbon Fibre, AL = Aluminium, P = Plastic
 F = Front, R = Rear

Ride Height **5.6** mm
 Camber **2.0** deg
 Droop **21.2** mm
 Castor **3.0** deg
 Toe **3.5** deg
 Anti Roll Bar 1.1 1.2 1.3 1.4
 Upper Link Mount 0 Notch 1 Notch
 Diff Height U8777 +0.5mm Alloy Eccentric U8729 High Trans Housing
 Diff Setting Diff Checker # _____ **5k** cSt Warming

Notes:

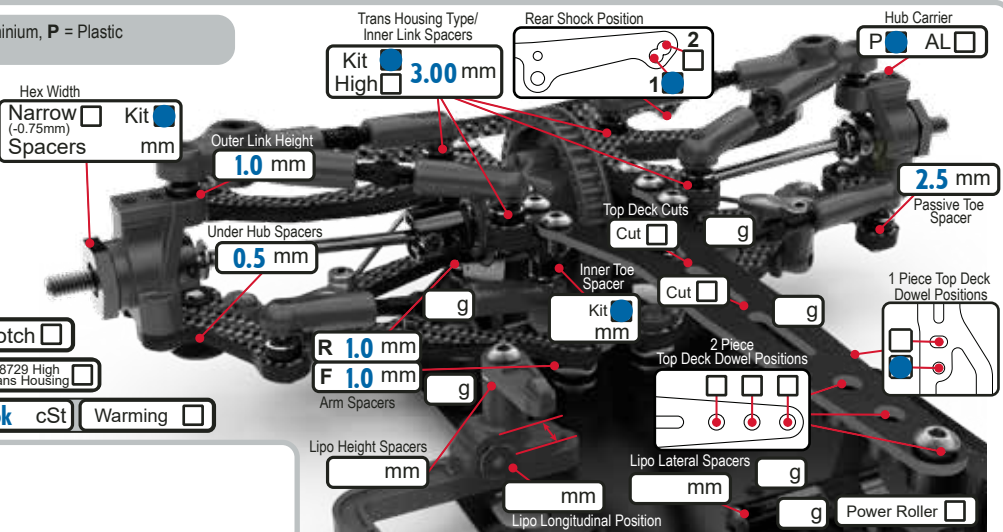

BODYSHELL

Body **Xtreme Speciale**
 Wing **Xtreme Twister**
 Wing Height _____ mm
 Splitter Height _____ mm
 Body Weight _____ g
 Body Offset Fwrd _____ mm
 Wing Offset Rwrdr _____ mm
 Wing End Plates
 Front Post 1dot 2dot 3dot Pin Hole **5**
 Rear Post 1dot 2dot 3dot Pin Hole **10**
 Notes:

CHASSIS

Chassis AL CF
 Top Deck Options CF 1 Piece 2mm
 Front 2 Piece S2 1.6 C/F 1.6 C/F 2.0
 Rear 2 Piece S2 1.6 C/F 1.6 C/F 2.0
 T Brace PTFE Tape
 Motor Mount Screws R F
 Total Weight _____ g
 Weight Distribution Front: _____ : _____ : _____ Rear

ELECTRONICS

E.S.C. _____ + g
 Servo _____
 RX _____ + g
 LiPo _____ + g
 Motor _____ Spacers mm
 Rotor Dia. _____ mm
 Timing _____ deg
 Gear Pitch 48 64
 Pinion _____ t
 Spur _____ t
 Ratio _____

SHOCKS

KEY: x = Stroke, e = external

	FRONT	REAR
Spring	Core-Rc Orange	Core-RC Black
Oil	400 cSt	400 cSt
Piston	Kit <input checked="" type="checkbox"/>	Kit <input type="checkbox"/>
Length (x)	8 mm	8 mm
Rebound	0 mm	0 mm
Limiters (e)	_____ mm	_____ mm
Body	Kit <input checked="" type="checkbox"/>	Kashima Coated <input type="checkbox"/>

Notes:

Driver: **Michal Orlowski** Track: **Daun** Event: **ETS R5 23/24**
 Date: **January 2024** Qualifying: Final: **1st** Best Lap: **11.6**

TRACK TYPE

Grip Level High Medium Low
 Type Tight Open Mixed
 Condition Flat Bumpy Mixed
 Surface Tarmac (Asphalt) Carpet
 Track Temp _____ °C
 Weather _____ **20**

Notes:

TYRES

Side Wall Glue Height Ø _____ mm
 Tyres **Matrix 28**
 Cleaner _____
 Additive **MR33-V4** Wet on track
 Additive Time Front: **10** mins Rear: **10** mins
 Heating Time Front: _____ mins Rear: _____ mins
 Heating Temp Front: _____ °C Rear: _____ °C

Notes:

Alloy Chassis - ETS WIN - Race Settings

FRONT

KEY: CF = Carbon Fibre, AL = Aluminium, P = Plastic
 F = Front, R = Rear

Ride Height **5.0** mm
 Camber **2.0** deg
 Droop **23.8** mm
 Castor **4.0** deg
 Toe **1.0/side** deg
 Anti Roll Bar 1.1 1.2 1.3 1.4
 Upper Link Mount 0 Notch 1 Notch
 Spool Height U8777 +0.5mm Alloy Eccentric U8729 High Trans Housing
 Servo Horn Height **17** mm Saver
 Steering Travel **26** in _____ out

Notes:

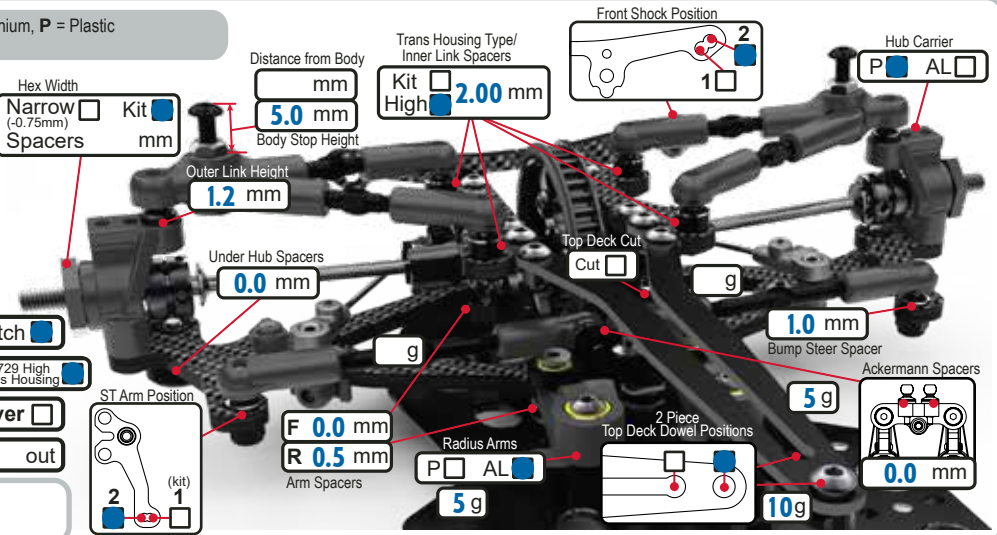

REAR

KEY: CF = Carbon Fibre, AL = Aluminium, P = Plastic
 F = Front, R = Rear

Ride Height **5.4** mm
 Camber **2.0** deg
 Droop **22.6** mm
 Castor **2.5** deg
 Toe **2.5** deg
 Anti Roll Bar 1.1 1.2 1.3 1.4
 Upper Link Mount 0 Notch 1 Notch
 Diff Height U8777 +0.5mm Alloy Eccentric U8729 High Trans Housing
 Diff Setting Diff Checker # _____ **6K** cSt Warming

Notes:

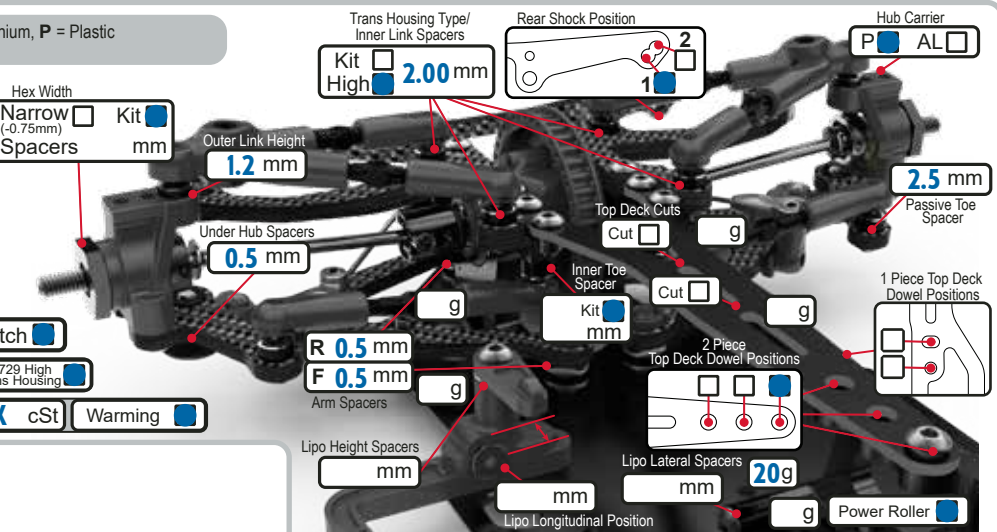

BODYSHELL

Body **Xtreme Speciale**
 Wing **Xtreme Twister**
 Wing Height _____ mm
 Splitter Height **7** mm
 Body Weight _____ g
 Body Offset Fwrd _____ mm
 Wing Offset Rwrdr _____ mm
 Wing End Plates
 Front Post 1dot 2dot 3dot Pin Hole **5**
 Rear Post 1dot 2dot 3dot Pin Hole **10**

Notes:

CHASSIS

Chassis AL CF
 Top Deck Options CF 1 Piece 2mm
 Front 2 Piece S2 1.6 Rear 2 Piece S2 1.6
 C/F 1.6 C/F 1.6
 C/F 2.0 C/F 2.0
 T Brace PTFE Tape
 Motor Mount Screws R F
 Total Weight **1280** g
 Weight Distribution Front: _____ : _____ : _____ Rear

ELECTRONICS

E.S.C. **Hobbywing** + g
 Servo **Power HD S15**
 RX **Sanwa RX-492** + g
 LiPo **Sunpadow 4000** + g
 Motor **Hobbywing 5T** Spacers _____ mm
 Rotor Dia. _____ mm
 Timing _____ deg
 Gear Pitch 48 64
 Pinion _____ t
 Spur _____ t
 Ratio _____

SHOCKS

KEY: x = Stroke, e = external

	FRONT	REAR
Spring	2.5-2.8	2.6
Oil	350 cSt	350 cSt
Piston	Kit <input checked="" type="checkbox"/>	Kit <input type="checkbox"/>
Length (x)	8 mm	8 mm
Rebound	0 mm	0 mm
Limiters (e)	_____ mm	_____ mm
Body	Kit <input checked="" type="checkbox"/>	Kashima Coated <input type="checkbox"/>

Notes:

Driver: _____ Track: _____ Event: _____
 Date: _____ Qualifying: _____ Final: _____ Best Lap: _____

TRACK TYPE

Grip Level High Medium Low
 Type Tight Open Mixed
 Condition Flat Bumpy Mixed
 Surface Tarmac (Asphalt) Carpet
 Track Temp _____ °C
 Weather _____

Notes:

TYRES

Side Wall Glue Height Ø _____ mm
 Tyres _____
 Cleaner _____
 Additive _____ Wet on track
 Additive Time Front: _____ mins Rear: _____ mins
 Heating Time Front: _____ mins Rear: _____ mins
 Heating Temp Front: _____ °C Rear: _____ °C

Notes:

FRONT

KEY: CF = Carbon Fibre, AL = Aluminium, P = Plastic
 F = Front, R = Rear

Ride Height _____ mm
 Camber _____ deg
 Droop _____ mm
 Castor _____ deg
 Toe _____ deg
 Anti Roll Bar 1.1 1.2 1.3 1.4
 Upper Link Mount 0 Notch 1 Notch
 Spool Height U8777 +0.5mm Alloy Eccentric U8729 High Trans Housing
 Servo Horn Height _____ mm Saver
 Steering Travel _____ in _____ out

Notes:

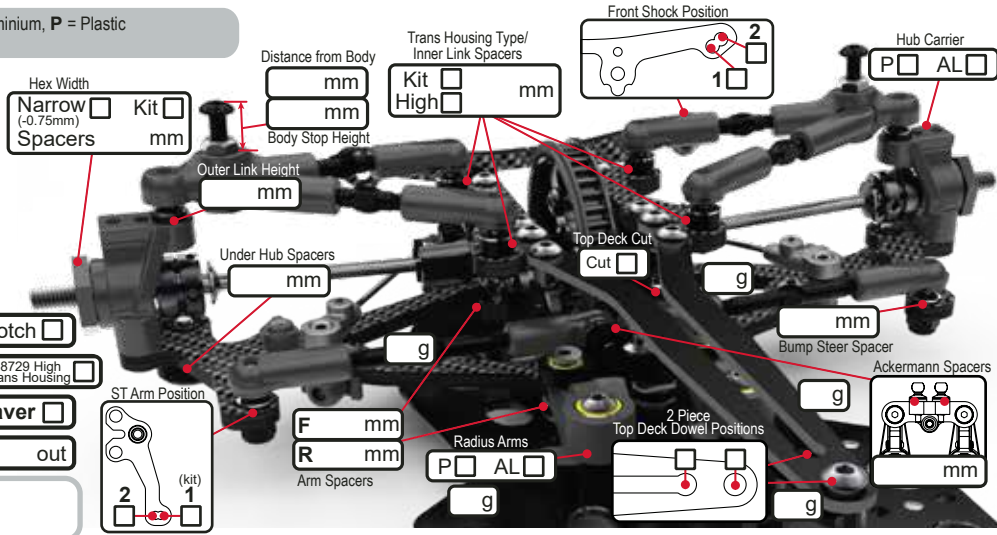

REAR

KEY: CF = Carbon Fibre, AL = Aluminium, P = Plastic
 F = Front, R = Rear

Ride Height _____ mm
 Camber _____ deg
 Droop _____ mm
 Castor _____ deg
 Toe _____ deg
 Anti Roll Bar 1.1 1.2 1.3 1.4
 Upper Link Mount 0 Notch 1 Notch
 Diff Height U8777 +0.5mm Alloy Eccentric U8729 High Trans Housing
 Diff Setting Diff Checker # _____ cSt Warming

Notes:

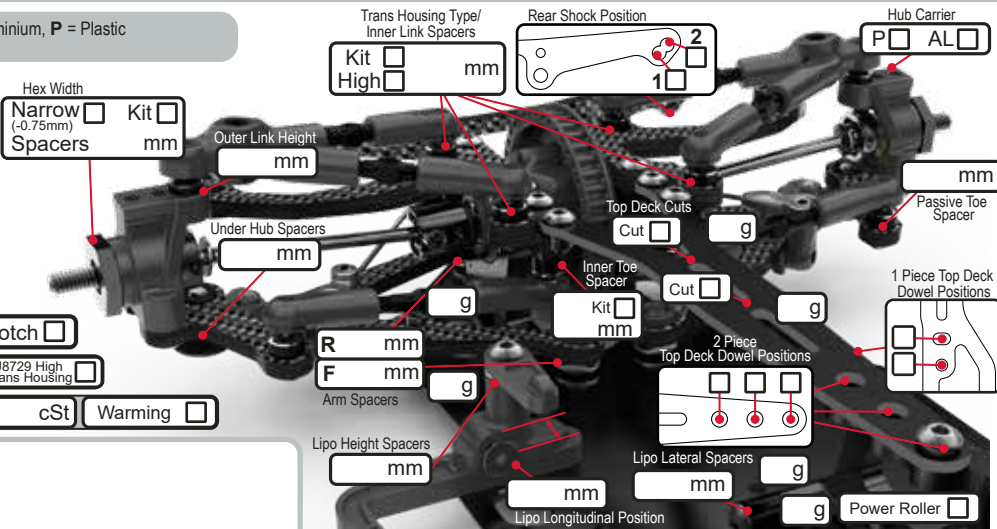

BODYSHELL

Body _____
 Wing _____
 Wing Height _____ mm
 Splitter Height _____ mm
 Body Weight _____ g
 Body Offset Fwrd _____ mm
 Wing Offset Rwrd _____ mm
 Wing End Plates
 Front Post 1dot 2dot 3dot Pin Hole
 Rear Post 1dot 2dot 3dot Pin Hole

Notes:

CHASSIS

Chassis AL CF
 Top Deck Options CF 1 Piece 2mm
 Front 2 Piece S2 1.6 C/F 1.6 C/F 2.0
 Rear 2 Piece S2 1.6 C/F 1.6 C/F 2.0
 T Brace PTFE Tape
 Motor Mount Screws R F
 Total Weight _____ g
 Weight Distribution Front: _____ : _____ : _____ Rear

ELECTRONICS

E.S.C. _____ + g
 Servo _____
 RX _____ + g
 LiPo _____ + g
 Motor _____ Spacers mm
 Rotor Dia. _____ mm
 Timing _____ deg
 Gear Pitch 48 64
 Pinion _____ t
 Spur _____ t
 Ratio _____

SHOCKS

KEY: x = Stroke, e = external

	FRONT	REAR
Spring	_____	_____
Oil	_____ cSt	_____ cSt
Piston	Kit <input type="checkbox"/>	Kit <input type="checkbox"/>
Length (x)	_____ mm	_____ mm
Rebound	_____ mm	_____ mm
Limiters (e)	_____ mm	_____ mm
Body	Kit <input type="checkbox"/>	Kashima Coated <input type="checkbox"/>

Notes: